



CATÁLOGO GENERAL
GENERAL CATALOGUE
CATALOGUE GÉNÉRAL

V.8

Future needs tools



CATÁLOGO GENERAL

GENERAL CATALOGUE

CATALOGUE GÉNÉRAL

V.8



Tayg

S I N C E
1964



MISIÓN / MISSION / MISSION

Facilitamos la organización con soluciones prácticas, duraderas e innovadoras, siempre cuidando el entorno.

We provide practical, durable, and innovative storage solutions while caring for the environment.

Nous proposons des solutions de rangement pratiques, durables et innovantes, tout en respectant l'environnement.



VISIÓN / VISION / VISION

Ser la referencia global en almacenamiento, destacando por calidad, innovación y atención al cliente.

To be the global reference in storage, known for quality, innovation, and customer focus.

Être la référence mondiale en rangement, reconnue pour sa qualité, son innovation et son attention client.



VALORES / VALUES / VALEURS

Creatividad útil, calidad real, cercanía, adaptabilidad, responsabilidad ambiental.

Practical Creativity, Real Quality, Closeness, Adaptability, Environmental Responsibility.

Créativité utile, Qualité réelle, Proximité, Adaptabilité, Responsabilité environnementale.

**NUESTRA
FILOSOFÍA**

**OUR
PHILOSOPHY**

**NOTRE
PHILOSOPHIE**

Future needs tools



Desde hace más de 60 años apostamos por la calidad en nuestros productos, en el servicio y en el cuidado del medio ambiente. El diseño y la innovación han sido pilares fundamentales de nuestro crecimiento continuo, siempre manteniendo el equilibrio entre la máxima calidad y la excelencia en la atención a nuestros clientes.

Contamos con una sólida estructura industrial y un gran potencial operativo, con una capacidad de transformación superior a 7.000 toneladas anuales, con 22 líneas de inyección y soplado. Gracias a una visión global en expansión y a una red internacional de agentes, estamos presentes en más de 40 países.

Nuestros productos están orientados a profesionales, al sector DIY y a todos los ámbitos vinculados a la construcción, el trabajo especializado y el bricolaje.



For more than 60 years, we have been committed to quality in our products, our service, and our environmental responsibility. Design and innovation have been essential pillars of our continuous growth, always maintaining the perfect balance between top quality and excellent customer service.

We have a strong industrial structure and significant operational capacity, with a transformation capability of over 7,000 tons per year, with 22 injection and blow moulding lines. Thanks to our expanding global vision and an international network of agents, we are present in more than 40 countries worldwide.

Our products are designed for professionals, the DIY sector, and all areas related to construction, specialized work, and home improvement.



Depuis plus de 60 ans, nous nous engageons pour la qualité de nos produits, de notre service et de notre responsabilité environnementale. Le design et l'innovation sont des piliers essentiels de notre croissance continue, tout en maintenant l'équilibre parfait entre la meilleure qualité et un service client d'excellence.

Nous disposons d'une solide structure industrielle et d'un fort potentiel opérationnel, avec une capacité de transformation de plus de 7 000 tonnes par an, avec 22 lignes d'injection et de soufflage. Grâce à notre vision globale en constante expansion et à un réseau international d'agents, nous sommes présents dans plus de 40 pays.

Nos produits s'adressent aux professionnels, au secteur du DIY, ainsi qu'à tous les domaines liés à la construction, aux travaux spécialisés et au bricolage.



CAPACIDAD DE PRODUCCIÓN
PRODUCTION CAPACITY
CAPACITÉ DE PRODUCTION

30.000m²

Instalaciones productivas
Production Facilities
Installations de Production

22

Líneas de inyección
Injection Lines
Lignes d'Injection

+410

Moldes activos
Active Molds
Moules Actifs

7.000h

Horas de diseño anuales
Annual Design Hours
Heures de Conception Annuelles





GARANTÍA DE CALIDAD Y MEDIOAMBIENTAL QUALITY AND ENVIRONMENTAL GUARANTEE GARANTIE DE QUALITÉ ET ENVIRONNEMENTALE



Trabajamos con plásticos
100% reciclables

We work with 100%
recyclable plastics

Nous travaillons avec
des plastiques 100 %
recyclables.



Medimos nuestra huella
de carbono anualmente

We measure our carbon
footprint annually

Nous mesurons notre
empreinte carbone
chaque année.



Plástico reciclado al año para
reducir el impacto ambiental

Recycled plastic per year to
reduce environmental impact

Plastique recyclé par
an pour réduire l'impact
environnemental



Control integral de procesos
para garantizar la calidad

Complete process control
to ensure quality

Contrôle intégral des
processus pour garantir
qualité et efficacité



Producimos con menos energía
para un futuro más sostenible

We produce with less energy for
a more sustainable future

Nous produisons avec moins
d'énergie pour un avenir plus
durable

ISO 9001:2015

BUREAU VERITAS
Certification



ISO 14001:2015

BUREAU VERITAS
Certification



ISO 45001:2015

BUREAU VERITAS
Certification



Sello REDUZCO, obtenido tras 4 años consecutivos obteniendo el certificado de Reducción de Huella de Carbono.

REDUZCO seal, obtained after four consecutive years of receiving the Carbon Footprint Reduction certificate.

Label REDUZCO, obtenu après avoir obtenu pendant 4 années consécutives le certificat de réduction de l'empreinte carbone.





Tayg

Tayg

ÍNDICE / INDEX

1

TAYG

- 11. ORGANIZACIÓN DE HERRAMIENTAS 10
TOOL ORGANISATION / ORGANISATION DES OUTILS
- 12. ORDENACIÓN / ARRANGEMENT / RANGEMENT 48
- 13. HOGAR / HOME / FOYER 74
- 14. EXTERIOR / OUTSIDE / EXTÉRIEUR 78

2

TAYG LIGHT

- 2.1. ENROLLACABLES / CABLE REELS / ENROULEUR 96
- 2.2. PROYECTOR LED / LED WORKLIGHT / PROJECTEUR LED 108
- 2.3. LÁMPARAS LED / PENLIGHT LED / LAMPES À LED 114
- 2.4. BASES MÚLTIPLES Y PROLONGADORES ELÉCTRICOS 118
MULTIPLE SOCKETS AND EXTENSION CABLES
PRISAS MULTIPLES ET RALLONGES

3

TAYG BUILD

- 3.1. DISTANCIADORES PAVIMENTO Y SISTEMAS DE NIVELACIÓN 126
WALL AND FLOOR SPACERS / ESPACEURS SOL ET MUR
- 3.2. SOPORTES PARA SUELOS ELEVADOS 136
SUPPORTS FOR ELEVATED FLOORS / SUPPORTS POUR SOLS SURÉLEVÉS
- 3.3. PAVÉS Y ACCESORIOS DE SEGURIDAD 154
GLASS BLOCK SPACER AND SAFETY ACCESSORIES
ENTRETOISE ET ACCESSOIRES
- 3.4. ACCESORIOS PARA ENCOFRADO 158
FORMWORK ACCESSORIES / ACCESSOIRES POUR COFFRAGE
- 3.5. CAPAZOS / FLEXITUB / SEAU DE CHANTIER 168



1 TAYG





500
Tagg
Caja de herramientas
500 piezas

1.1

ORGANIZACIÓN DE HERRAMIENTAS TOOL ORGANISATION ORGANISATION DES OUTILS

1.1.1. CAJAS DE HERRAMIENTAS 12
TOOL BOXES/ BOÎTES À OUTILS

1.1.2. SISTEMA MODULAR 24
MODULAR SYSTEM/ SYSTÈME MODULAIRE

1.1.3. COFRE DE HERRAMIENTAS MÓVIL 28
MOBILE TOOL CHEST / COFFRE A OUTILS MOBILE

1.1.4. TRAIL BOX 30
TRAIL BOX/ SERVANTER DE CHANTIER

1.1.5. ESTUCHES 32
ORGANIZERS / COFFRETS

1.1.6. MULTIBOX 38
MULTIBOX / MULTIBOX

1.1.7. MALETAS HERRAMIENTAS ELÉCTRICAS 40
CASES FOR ELECTRICAL TOOLS / MALLETTES POUR OUTILLAGE ÉLECTRIQUE

1.1.8. BASIC LINE 42
BASIC LINE/ BASIC LINE

1.1.9. TEXTIL: BOLSAS, MOCHILAS Y CINTURONES 44
TEXTILES: BAGS, BACKPACKS AND BELTS/ TEXTILE : SACS, SACS À DOS ET CEINTURES



CAJAS
BOXES
BOÎTES

1.1 CAJAS DE HERRAMIENTAS TOOL BOXES BOÎTES À OUTILS

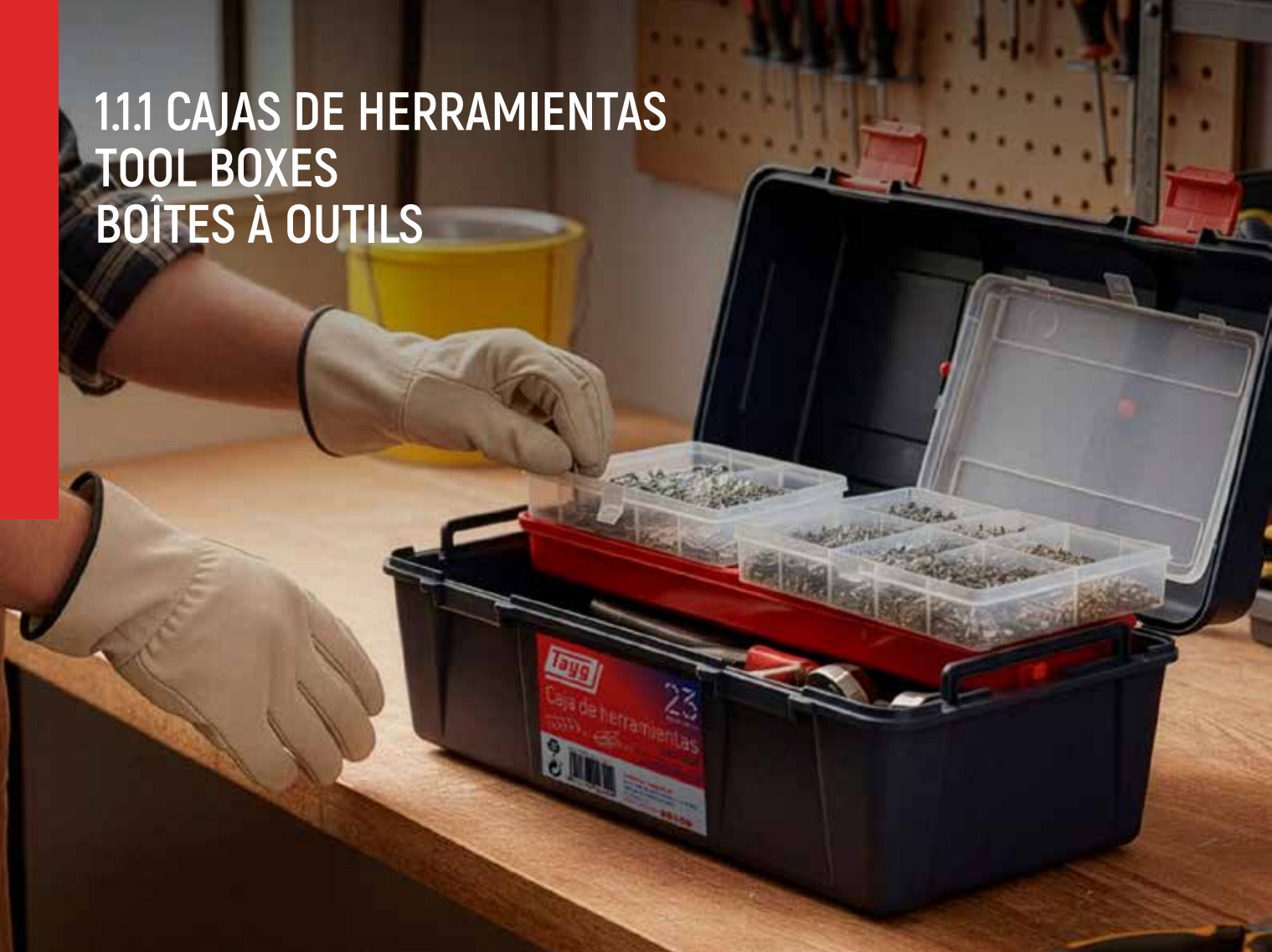

121005



122002



123009

CÓDIGO CODE	MODELO MODEL / MODÈLE	L x A x H MEDIDAS SIZES / MESURES	CONTIENE CONTAINED / CONTIENT	MATERIAL MATERIAL / MATÉRIAU	EMBALAJE / UNIDADES PACKING / UNITS EMBALLAGE / UNITÉS
121005	21	310 x 160 x 130 mm 12,20 x 6,30 x 5,12 in	1 Bandeja / Tray / Panier porte-outils	PP	10
122002	22	356 x 184 x 163 mm 14,02 x 7,24 x 6,42 in	1 Bandeja / Tray / Panier porte-outils	PP	6
123009	23	356 x 184 x 163 mm 14,02 x 7,24 x 6,42 in	1 Bandeja / Tray / Panier porte-outils 1 Estuche / Organizer / Coffret	PP	6



CAJAS
BOXES
BOÎTES



Producto de alta calidad diseñado para satisfacer las necesidades tanto de profesionales como de aficionados al bricolaje.

High quality product designed to meet the needs of both professionals and DIY enthusiasts.

Produit de haute qualité conçu pour répondre aux besoins des professionnels et des bricoleurs.



124006



125003

CÓDIGO CODE	MODELO MODEL / MODÈLE	L x A x H MEDIDAS SIZES / MESURES	CONTIENE CONTAINED / CONTIENT	MATERIAL MATERIAL / MATÉRIAU	EMBALAJE / UNIDADES PACKING / UNITS EMBALLAGE / UNITÉS
124006	24	400 x 206 x 188 mm 15,75 x 8,11 x 7,40 in	1 Bandeja / Tray / Panier porte-outils	PP	6
125003	25	400 x 206 x 188 mm 15,75 x 8,11 x 7,40 in	1 Bandeja / Tray / Panier porte-outils 1 Estuche / Organize / Coffret	PP	6

1.1 CAJAS DE HERRAMIENTAS TOOL BOXES BOÎTES À OUTILS

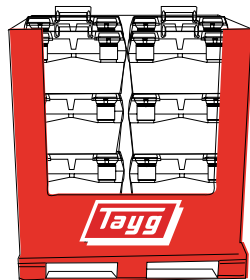

*OPCIÓN BOX PALLET / BOX PALLET OPTION / OPTION BOX PALLETTE



109003



110009



111006





NEW

111198



112003

CÓDIGO CODE	MODELO MODEL MODÈLE	L x A x H MEDIDAS SIZES / MESURES	CONTIENE CONTAINED / CONTIENT	MATERIAL MATERIAL MATÉRIAU	EMBALAJE / UNIDADES PACKING / UNITS EMBALLAGE / UNITÉS
109003	9	290 x 170 x 127 mm 11,42 x 6,69 x 5 in	Vacio / Empty / Vide	PP	10
110009	10	290 x 170 x 127 mm 11,42 x 6,69 x 5 in	1 Bandeja / Tray / Panier porte-outils	PP	10
111006	11	356 x 192 x 150 mm 14,02 x 7,56 x 5,91 in	1 Bandeja / Tray / Panier porte-outils	PP	6 
111198	11 ECO	356 x 192 x 150 mm 14,02 x 7,56 x 5,91 in	1 Bandeja / Tray / Panier porte-outils	PP	6
112003	12	400 x 217 x 166 mm 15,75 x 8,54 x 6,53 in	1 Bandeja / Tray / Panier porte-outils	PP	6 



CAJAS
BOXES
BOÎTES



115004



116001



117008



118005

CÓDIGO CODE	MODELO MODEL MODÈLE	L x A x H MEDIDAS SIZES / MESURES	CONTIENE CONTAINED / CONTIENT	MATERIAL MATERIAL MATÉRIAU	EMBALAJE / UNIDADES PACKING / UNITS EMBALLAGE / UNITÉS
115004	15	500 x 258 x 255 mm 19,68 x 10,16 x 10,04 in	1 Bandeja / Tray / Panier porte-outils	PP Cierres metálicos / Metallic locks / Fermetures Métallique	3
116001	16	500 x 258 x 255 mm 19,68 x 10,16 x 10,04 in	1 Bandeja / Tray / Panier porte-outils 1 Estuche / Organize / Coffret	PP Cierres metálicos / Metallic locks / Fermetures Métallique	3
117008	17	580 x 290 x 290 mm 22,83 x 11,42 x 11,42 in	1 Bandeja / Tray / Panier porte-outils	PP Cierres metálicos / Metallic locks / Fermetures Métallique	3
118005	18	580 x 290 x 290 mm 22,83 x 11,42 x 11,42 in	1 Bandeja / Tray / Panier porte-outils 1 Estuche / Organize / Coffret	PP Cierres metálicos / Metallic locks / Fermetures Métallique	3

1.1.1 CAJAS DE HERRAMIENTAS TOOL BOXES BOÎTES À OUTILS



130007



131004



132001

CÓDIGO CODE	MODELO MODEL MODÈLE	L x A x H MEDIDAS SIZES / MESURES	CONTIENE CONTAINED / CONTIENT	MATERIAL MATERIAL MATÉRIAU	EMBALAJE / UNIDADES PACKING / UNITS EMBALLAGE / UNITÉS
130007	30	445 x 235 x 230 mm 17,52 x 9,25 x 9,05 in	1 Bandeja / Tray / Panier porte-outils	PP	6
131004	31	445 x 235 x 230 mm 17,52 x 9,25 x 9,05 in	1 Bandeja / Tray / Panier porte-outils 1 Estuche / Organizer / Coffret	PP	6
132001	32	480 x 258 x 255 mm 18,90 x 10,16 x 10,04 in	1 Bandeja / Tray / Panier porte-outils	PP	3

PROFESIONAL



CAJAS
BOXES
BOÎTES



133008



133190



134005



134999



135002



136009

CÓDIGO CODE	MODELO MODEL MODÈLE	L x A x H MEDIDAS SIZES / MESURES	CONTIENE CONTAINED / CONTIENT	MATERIAL MATERIAL MATÉRIAU	EMBALAJE / UNIDADES PACKING / UNITS EMBALLAGE / UNITÉS
133008	33	480 x 258 x 255 mm 18,90 x 10,16 x 10,04 in	1 Bandeja / Tray / Panier porte-outils 1 Estuche / Organize / Coffret	PP	3
133190	33 PRO	480 x 258 x 255 mm 18,90 x 10,16 x 10,04 in	1 Bandeja / Tray / Panier porte-outils	PP Cierres metálicos / Metallic locks / Fermetures Métallique	3
134999	34-1B	580 x 285 x 290 mm 22,83 x 11,22 x 11,42 in	1 Bandeja / Tray / Panier porte-outils	PP	3
134005	34	580 x 285 x 290 mm 22,83 x 11,22 x 11,42 in	1 Bandeja / Tray / Panier porte-outils 1 Estuche / Organize / Coffret	PP	3
135002	35	580 x 285 x 290 mm 22,83 x 11,22 x 11,42 in	2 Bandeja / Tray / Panier porte-outils 1 Estuche / Organize / Coffret	PP	3
136009	36	580 x 285 x 290 mm 22,83 x 11,22 x 11,42 in	1 Bandeja doble / Double tray / Panier porte-outils 1 Estuche / Organize / Coffret	PP	3

1.1 CAJAS DE HERRAMIENTAS TOOL BOXES BOÎTES À OUTILS



NEW



CÓDIGO CODE	MODELO MODEL MODÈLE	L x A x H MEDIDAS SIZES / MESURES	CONTIENE CONTAINED / CONTIENT	MATERIAL MATERIAL / MATÉRIAU	EMBALAJE / UNIDADES PACKING / UNITS EMBALLAGE / UNITÉS
146039	●	499 x 279 x 254 mm 19,65 x 11 x 10 in	1 Bandeja / Tray / Panier porte-outils 1 Estuche exterior / Out organize / Coffret externe	PP Cierres metálicos / Metallic locks / Fermetures Métallique	3
146022	●	499 x 279 x 254 mm 19,65 x 11 x 10 in	1 Bandeja / Tray / Panier porte-outils 1 Estuche / Organize / Coffret	PP Cierres metálicos / Metallic locks / Fermetures Métallique	3
146077	●	499 x 279 x 254 mm 19,65 x 11 x 10 in	1 Bandeja / Tray / Panier porte-outils 1 Estuche / Organize / Coffret	PP Cierres metálicos / Metallic locks / Fermetures Métallique	3



146039



146022



146077



CIERRE SEGURO
SAFE LOCKING
VERROUILLAGE SÉCURISÉ



COMODIDAD
COMFORT
CONFORT



VERSATILIDAD
VERSATILITY
POLYVALENCE





1.1 CAJAS DE HERRAMIENTAS TOOL BOXES BOÎTES À OUTILS



162008



163005



164002

CÓDIGO CODE	MODELO MODEL MODÈLE	L x A x H MEDIDAS SIZES / MESURES	CONTIENE CONTAINED / CONTIENT	MATERIAL MATERIAL / MATÉRIAU	EMBALAJE / UNIDADES PACKING / UNITS EMBALLAGE / UNITÉS
162008	400	400 x 225 x 190 mm 15,75 x 8,86 x 7,48 in	1 Bandeja / Tray / Panier porte-outils	PP	6
163005	450	450 x 285 x 250 mm 17,72 x 11,22 x 9,84 in	1 Bandeja / Tray / Panier porte-outils	PP Asa Aluminio / Aluminium handle Poignée Aluminium Cierres metálicos / Metallic locks Attaches Métalliques	3
164002	450-E	450 x 285 x 250 mm 17,72 x 11,22 x 9,84 in	1 Bandeja / Tray / Panier porte-outils 1 Estuche / Organize / Coffret	PP Asa Aluminio / Aluminium handle Poignée Aluminium Cierres metálicos / Metallic locks Attaches Métalliques	3

PROFESIONAL



CAJAS
BOXES
BOÎTES



Cierres metálicos
Metallic locks
Attaches Métalliques

Estuche transparente de PP para pequeños objetos
PP transparent organize for small items
Coffret transparent en PP pour les petits objets

Bandeja de PP roja
PP red tray
Painer porte-outils en PP rouge



CÓDIGO CODE	MODELO MODEL MODÈLE	L x A x H MEDIDAS SIZES / MESURES	CONTIENE CONTAINED / CONTIENT	MATERIAL MATERIAL / MATÉRIAU	EMBALAJE / UNIDADES PACKING / UNITS EMBALLAGE / UNITÉS
165009	500	500 x 295 x 270 mm 19,68 x 11,61 x 10,63 in	1 Bandeja / Tray Panier porte-outils	PP Asa Aluminio / Aluminium handle / Poignée Aluminium Cierres metálicos / Metallic locks / Attaches Métalliques	3
166006	500-E	500 x 295 x 270 mm 19,68 x 11,61 x 10,63 in	1 Bandeja / Tray Panier porte-outils 1 Estuche / Organize / Coffret	PP Asa Aluminio / Aluminium handle / Poignée Aluminium Cierres metálicos / Metallic locks / Attaches Métalliques	3

1.1 CAJAS DE HERRAMIENTAS TOOL BOXES BOÎTES À OUTILS



167003



168000



168192

CÓDIGO CODE	MODELO MODEL MODÈLE	L x A x H MEDIDAS SIZES / MESURES	CONTIENE CONTAINED / CONTIENT	MATERIAL MATERIAL / MATÉRIAU	EMBALAJE / UNIDADES PACKING / UNITS EMBALLAGE / UNITÉS
167003	600	600 x 305 x 295 mm 23,62 x 12,01 x 11,61 in	1 Bandeja / Tray / Panier porte-outils	PP Asa Aluminio / Aluminium handle / Poignée Aluminium Cierres metálicos / Metallics locks / Attaches Métalliques	3
168000	600-E	600 x 305 x 295 mm 23,62 x 12,01 x 11,61 in	1 Bandeja / Tray / Panier porte-outils 1 Estuche / Organize / Coffret	PP Asa Aluminio / Aluminium handle / Poignée Aluminium Cierres metálicos / Metallics locks / Attaches Métalliques	3
168192	600 PRO	600 x 305 x 295 mm 23,62 x 12,01 x 11,61 in	1 Bandeja / Tray / Panier porte-outils 1 Estuche exterior / Out organize / Coffret externe	PP Asa Aluminio / Aluminium handle / Poignée Aluminium Cierres metálicos / Metallics locks / Attaches Métalliques	3

PROFESIONAL



CAJAS
BOXES
BOÎTES



Cerrado
Closed
Fermé

Abierto
Opened
Ouvert



NEW

173219



170003



171000



172007



173004

CÓDIGO CODE	MODELO MODEL MODÈLE	L x A x H MEDIDAS SIZES / MESURES	CONTIENE CONTAINED / CONTIENT	MATERIAL MATERIAL / MATÉRIAU	EMBALAJE / UNIDADES PACKING / UNITS EMBALLAGE / UNITÉS
170003	550 - B	550 x 300 x 275 mm 21,65 x 11,81 x 10,83 in	1 Bandeja / Tray Panier porte-outils	PP Asa Aluminio / Aluminium handle / Poignée Aluminium Cierres metálicos / Metallics locks / Attaches Métalliques	3
171000	550 - E	550 x 300 x 275 mm 21,65 x 11,81 x 10,83 in	1 Estuche / Organize / Coffret	PP Asa Aluminio / Aluminium handle / Poignée Aluminium Cierres metálicos / Metallics locks / Attaches Métalliques	3
172007	650 - B	650 x 300 x 295 mm 25,59 x 11,81 x 11,61 in	1 Bandeja / Tray / Panier porte-outils	PP Asa Aluminio / Aluminium handle / Poignée Aluminium Cierres metálicos / Metallics locks / Attaches Métalliques	2
173004	650 - E	650 x 300 x 295 mm 25,59 x 11,81 x 11,61 in	1 Estuche / Organize / Coffret	PP Asa Aluminio / Aluminium handle / Poignée Aluminium Cierres metálicos / Metallics locks / Attaches Métalliques	2
173219	650 - TE	650 x 300 x 295 mm 25,59 x 11,81 x 11,61 in	1 Estuche / Organize / Coffret	PP Asa Aluminio / Aluminium handle / Poignée Aluminium Cierres metálicos / Metallics locks / Attaches Métalliques	1



1.1.2. SISTEMA MODULAR CON CIERRE CANGREJO MODULAR SYSTEM WITH SAFETY LATCH SYSTÈME MODULAIRE AVEC ATTACHES DE SÉCURITÉ

NEW



- **Versatilidad:** Separadores y módulos combinables; cajas adaptables en el trolley y euroroller.
- **Resistencia:** Cada caja soporta hasta 30 kg internos y 120 kg externos.
- **Gran capacidad de almacenamiento:** Múltiples tamaños permiten organizar herramientas, accesorios y pequeños objetos.
- **Versatility:** Interchangeable dividers and modules; boxes fit on the trolley and euroroller.
- **Strength:** Each box holds 30 kg inside and 120 kg externally.
- **High storage capacity:** Various sizes allow organizing tools, accessories, and small items.
- **Polyvalence:** Séparateurs et modules combinables ; boîtes adaptables sur le chariot et l'euroroller.
- **Résistance:** Chaque boîte supporte 30 kg à l'intérieur et 120 kg à l'extérieur.
- **Grande capacité de stockage:** Différentes tailles permettent de ranger outils, accessoires et petits objets.



199004

198007

CÓDIGO CODE	MODELO MODEL MODÈLE	L x A x H MEDIDAS SIZES / MESURES	CONTIENE CONTAINED / CONTIENT	MATERIAL MATERIAL MATÉRIAU	EMBALAJE / UNIDADES PACKING / UNITS EMBALLAGE / UNITÉS
199004	Sistema modular apilable pro cierre cangrejo IP66 con euro-roller	500 x 410 x 770 mm 19.69 x 16.14 x 30.31 in	Caja M / M box / Boîte M Caja L / L box / Boîte L Caja XL / XL box / Boîte XL Euro-roller	PP Cierres metálicos / Metallic locks / Attaches Métalliques	1
198007	Sistema modular apilable pro cierre cangrejo IP66 con trolley	500 x 390 x 770 mm 19.69 x 15.35 x 30.31 in	Caja M / M box / Boîte M Caja L / L box / Boîte L Caja XL / XL box / Boîte XL Carro / Trolley / Chariot	PP Cierres metálicos / Metallic locks / Attaches Métalliques	1

PROFESIONAL



CAJAS
BOXES
BOÎTES

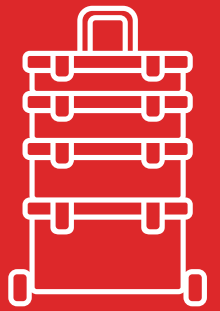

CÓDIGO CODE	MODELO MODEL MODÈLE	EMBALAJE / UNIDADES PACKING / UNITS EMBALLAGE / UNITÉS
199899	Euro-roller	1
198892	Carro / Trolley / Chariot	1



199899



198892

CIERRE CANGREJO
SAFETY LACH
ATTACHE DE SÉCURITÉ

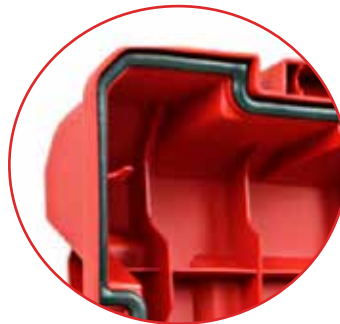

JUNTA IP66
JOINT IP66
CONSEIL IP66



176005



177002



178009

CÓDIGO CODE	MODELO MODEL MODÈLE	L x A x H MEDIDAS SIZES / MESURES	CONTIENE CONTAINED / CONTIENT	MATERIAL MATERIAL MATÉRIAU	EMBALAJE / UNIDADES PACKING / UNITS EMBALLAGE / UNITÉS
176005	Caja Modular «M» cierre cangrejo IP66	590 x 345 x 244 mm 23.23 x 13.58 x 9.61 in	1 Bandeja / Tray / Panier porte-outils 1 Estuche / Organize / Coffret	PP Cierres metálicos / Metallic locks / Attaches Métalliques	1
177002	Caja Modular «L» cierre cangrejo IP66	590 x 345 x 324 mm 23.23 x 13.58 x 12.76 in	1 Bandeja / Tray / Panier porte-outils 1 Estuche / Organize / Coffret	PP Cierres metálicos / Metallic locks / Attaches Métalliques	1
178009	Caja Modular «XL» cierre cangrejo IP66	590 x 345 x 404 mm 23.23 x 13.58 x 15.91 in	1 Bandeja / Tray / Panier porte-outils 1 Estuche / Organize / Coffret	PP Cierres metálicos / Metallic locks / Attaches Métalliques	1

CAJAS
BOXES
BOÎTES



1.1.2. SISTEMA MODULAR CON CIERRE METÁLICO MODULAR SYSTEM WITH METAL LOCK SYSTÈME MODULAIRE AVEC FERMETURE MÉTALLIQUE

NEW



176012

177019

178016

CÓDIGO CODE	MODELO MODEL MODÈLE	L x A x H MEDIDAS SIZES / MESURES	CONTIENE CONTAINED / CONTIENT	MATERIAL MATERIAL MATÉRIAU	EMBALAJE / UNIDADES PACKING / UNITS EMBALLAGE / UNITÉS
176012	Caja Modular «M» cierre metal	590 x 345 x 244 mm 23.23 x 13.58 x 9.61 in	1 Bandeja / Tray / Panier porte-outils 1 Estuche / Organize / Coffret	PP Cierres metálicos / Metallic locks / Attaches Métalliques	1
177019	Caja Modular «L» cierre metal	590 x 345 x 324 mm 23.23 x 13.58 x 12.76 in	1 Bandeja / Tray / Panier porte-outils 1 Estuche / Organize / Coffret	PP Cierres metálicos / Metallic locks / Attaches Métalliques	1
178016	Caja Modular «XL» cierre metal	590 x 345 x 404 mm 23.23 x 13.58 x 15.91 in	1 Bandeja / Tray / Panier porte-outils 1 Estuche / Organize / Coffret	PP Cierres metálicos / Metallic locks / Attaches Métalliques	1

PROFESIONAL



CAJAS
BOXES
BOÎTES

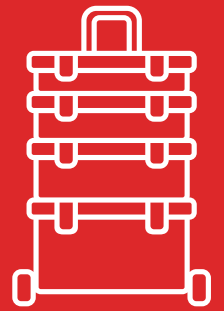

CÓDIGO CODE	MODELO MODEL MODÈLE	EMBALAJE / UNIDADES PACKING / UNITS EMBALLAGE / UNITÉS
199899	Euro-roller	1
198892	Carro / Trolley / Chariot	1



199899



198892

CIERRE METÁLICO
METAL LOCK
FERMETURE MÉTALLIQUE



199011



198014

- **Versatilidad:** Separadores y módulos combinables; cajas adaptables en el trolley y euroroller.
- **Resistencia:** Cada caja soporta hasta 30 kg internos y 120 kg externos.
- **Gran capacidad de almacenamiento:** Múltiples tamaños permiten organizar herramientas, accesorios y pequeños objetos.
- **Versatility:** Interchangeable dividers and modules; boxes fit on the trolley and euroroller.
- **Strength:** Each box holds 30 kg inside and 120 kg externally.
- **High storage capacity:** Various sizes allow organizing tools, accessories, and small items.
- **Polyvalence:** Séparateurs et modules combinables ; boîtes adaptables sur le chariot et l'euroroller.
- **Résistance:** Chaque boîte supporte 30 kg à l'intérieur et 120 kg à l'extérieur.
- **Grande capacité de stockage:** Différentes tailles permettent de ranger outils, accessoires et petits objets.

CÓDIGO CODE	MODELO MODEL MODÈLE	L x A x H MEDIDAS SIZES / MESURES	CONTIENE CONTAINED / CONTIENT	MATERIAL MATERIAL MATÉRIAU	EMBALAJE / UNIDADES PACKING / UNITS EMBALLAGE / UNITÉS
199011	Sistema modular apilable pro cierre metal con euro-roller	500 x 410 x 770 mm 19.69 x 16.14 x 30.31 in	Caja M / M box / Boîte M Caja L / L box / Boîte L Caja XL / XL box / Boîte XL Euro-roller	PP Cierres metálicos / Metallics locks / Attaches Métalliques	1
198014	Sistema modular apilable pro cierre metal con trolley	500 x 390 x 770 mm 19.69 x 15.35 x 30.31 in	Caja M / M box / Boîte M Caja L / L box / Boîte L Caja XL / XL box / Boîte XL Carro / Trolley / Chariot	PP Cierres metálicos / Metallics locks / Attaches Métalliques	1

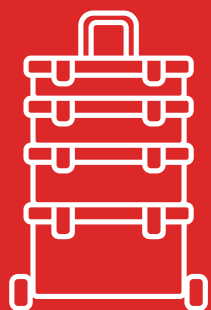

1.1.3. COFRE HERRAMIENTAS MÓVIL MOBILE TOOL CHEST COFFRE A OUTILS MOBILE

PROFESIONAL

NEW
154195



PALOMILLAS
BRACKETS
ÉCROU MOLETÉ



150005



151002



153006



154003

CÓDIGO CODE	MODELO MODEL MODÈLE	L x A x H MEDIDAS SIZES / MESURES	CONTIENE CONTAINED / CONTIENT	MATERIAL MATERIAL MATÉRIAU	EMBALAJE / UNIDADES PACKING / UNITS EMBALLAGE / UNITÉS
150005	50	675 x 472 x 416 mm 26,57 x 18,58 x 16,38 in	2 Bandejas / Tray / Panier porte-outils 5 Palomillas / Small Bracket / Écrou moleté	PP	1
151002	51	675 x 472 x 416 mm 26,57 x 18,58 x 16,38 in	2 Bandejas / Tray / Panier porte-outils 2 Estuche / Organizer / Coffrett	PP	1
153006	53	775 x 472 x 493 mm 30,51 x 18,58 x 19,41 in	2 Bandejas / Tray / Panier porte-outils 5 Palomillas / Small Bracket / Écrou moleté	PP	1
154003	54	775 x 472 x 493 mm 30,51 x 18,58 x 19,41 in	2 Bandejas / Tray / Panier porte-outils 2 Estuche / Organizer / Coffrett	PP	1
154195	54 PRO	775 x 472 x 493 mm 30,51 x 18,58 x 19,41 in	1 Bandeja / Tray / Panier porte-outils	PP Cierres metálicos / Metallic locks / Attaches Métalliques	1

KIT Cofre 54 PRO + Caja modular "M"
 KIT Box 54 PRO + Modular box "M" KIT
 Chest 54 PRO + Boîte modulaire "M"



NEW
998737



CÓDIGO CODE	MODELO MODEL MODÈLE	L x A x H MEDIDAS SIZES / MESURES	CONTIENE CONTAINED CONTIENT	MATERIAL MATERIAL / MATÉRIAU	EMBALAJE / UNIDADES PACKING / UNITS EMBALLAGE / UNITÉS
998737	54 PRO + CAJA MODULAR M	775 x 472 x 750 mm 30,51 x 18,58 x 29,53 in	1 Bandeja / Tray / Panier porte-outils 1 Estuche / Organizer / Coffret	PP Cierres metálicos / Metallic locks / Attaches Métalliques Asa (PP+Aluminio) / Handle (PP+Aluminium) / Manche (PP+Aluminium)	1
199905	ADAPTADOR Adapter Adaptateur	-	-	ADAPTADOR CAJA MODULAR - TAPA COFRE + 2 adaptadores + accesorios fijación MODULAR BOX ADAPTER - BOX COVER + 2 adapters + fixing accessories ADAPTATEUR DE BOÎTE MODULAIRE - COUVERCLE DE BOÎTE + 2 adaptateurs + accessoires de fixation	1



199905

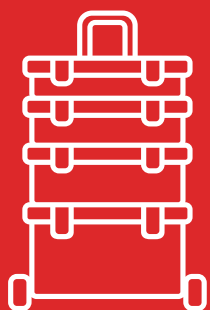

1.1.4. TRAIL BOX TRAIL BOX SERVANTER DE CHANTIER

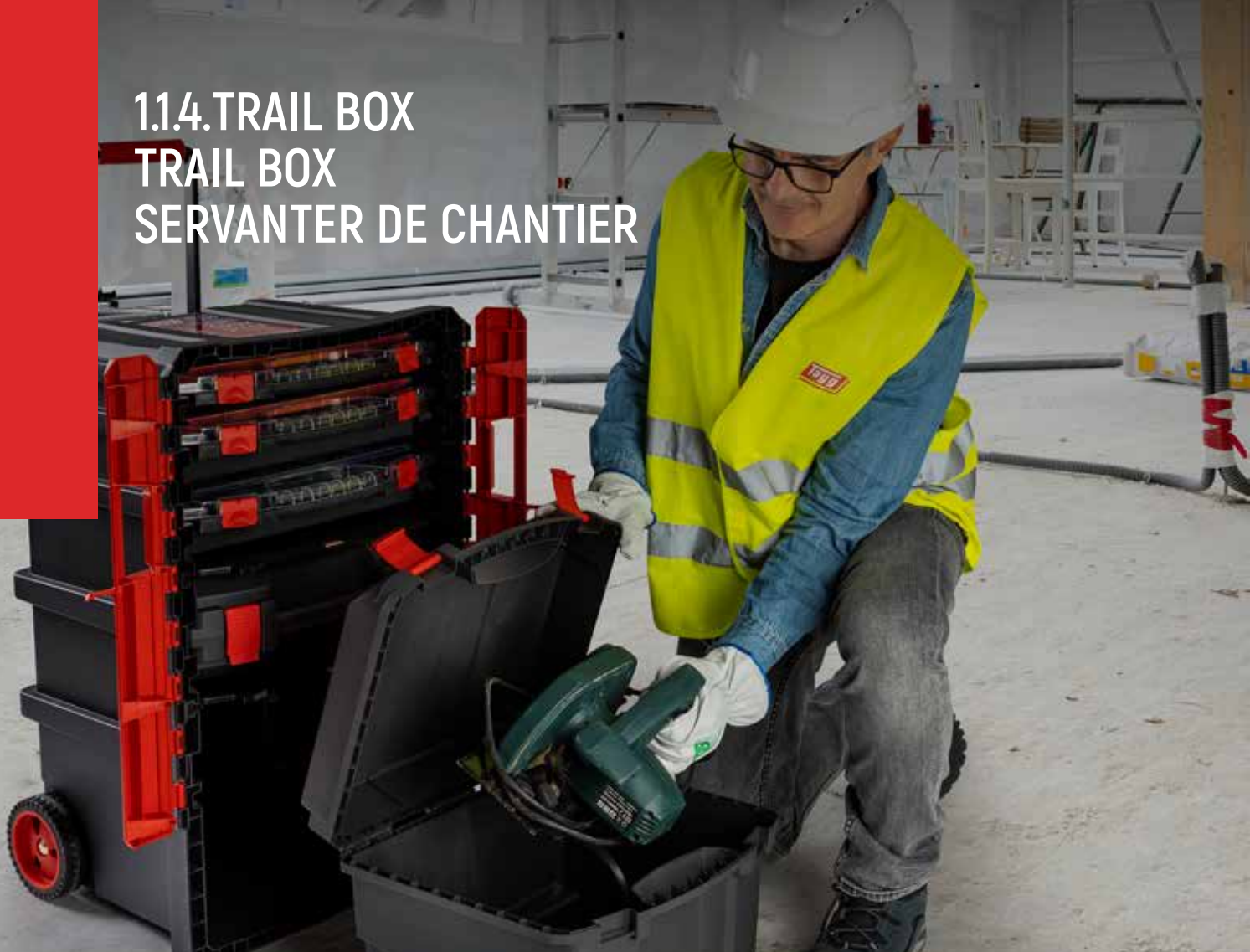

CÓDIGO CODE	MODELO MODEL MODÈLE	L x A x H MEDIDAS SIZES / MESURES	CONTIENE CONTAINED / CONTIENT	MATERIAL MATERIAL MATÉRIAU	EMBALAJE / UNIDADES PACKING / UNITS EMBALLAGE / UNITÉS
159008	59 PRO	500 x 410 x 770 mm 19,68 x 16,14 x 30,31 in	1 Estuche 430/50/25 / Organizer / Coffret 1 Estuche 430/80/13 / Organizer / Coffret 1 Estuche 430/80/0 / Organizer / Coffret 1 Maleta 44B / Bag / Mallette 1 Maleta cajón / Drawer sultcase / Mallette tiroir	PP Cajones y tapa transparente-PS Drawers and transparent cover-PS Tiroirs et couvercles transparents-PS	1

CONTIENE / CONTAINED / CONTIENT:



159008



1 Estuche 430/50/25
Organizer / Coffret



1 Estuche 430/80/13
Organizer / Coffret



1 Estuche 430/80/0
Organizer / Coffret



1 Maleta 44B / Bag
Mallette



1 Maleta Cajón
Drawer sultcase
Mallette tiroir



- Cierre de seguridad: levantar y girar para abrir
- Security lock: pull up and turn to open
- Fermeture de sécurité: lever et tourner pour ouvrir

PROFESIONAL



CAJAS
BOXES
BOÎTES

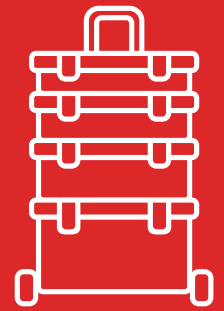

CÓDIGO CODE	MODELO MODEL MODÈLE	L x A x H MEDIDAS SIZES / MESURES	CONTIENE CONTAINED / CONTIENT	MATERIAL MATERIAL MATÉRIAU	EMBALAJE / UNIDADES PACKING / UNITS EMBALLAGE / UNITÉS
157004	57	470 x 290 x 630 mm 18,50 x 11,42 x 24,80 in	1 Bandeja / Tray / Panier porte-outils	PP	1
157196	57 PREMIUM	470 x 290 x 630 mm 18,50 x 11,42 x 24,80 in	1 Bandeja / Tray / Panier porte-outils	PP Cierres metálicos Metallic locks Attaches Métalliques	1
158001	58	470 x 290 x 630 mm 18,50 x 11,42 x 24,80 in	1 Bandeja / Tray / Panier porte-outils 1 Estuches/ Organizer / Coffret	PP Cierres metálicos Metallic locks Attaches Métalliques	1



1.1.5. ESTUCHES CON SEPARADORES FIJOS ORGANIZERS WITH FIXED DISTRIBUTION COFFRET À CASIERS FIXES

CÓDIGO CODE	MODELO MODEL MODÈLE	L x A x H MEDIDAS SIZES / MESURES	EMBALAJE / UNIDADES PACKING / UNITS EMBALLAGE / UNITÉS
050107	11-12	250 x 140 x 54 mm 9.84 x 5.51 x 2.13 in	6
051104	11-7	250 x 140 x 54 mm 9.84 x 5.51 x 2.13 in	6
060106	12-21	290 x 195 x 54 mm 11.42 x 7.68 x 2.13 in	6
061103	12-11	290 x 195 x 54 mm 11.42 x 7.68 x 2.13 in	6
008009	33-15	215 x 207 x 42 mm 8.47 x 8.15 x 1.65 in	12
009006	33-9	215 x 207 x 42 mm 8.47 x 8.15 x 1.65 in	12
070105	13-32	330 x 247 x 54 mm 12.99 x 9.72 x 2.13 in	6
071102	13-17	330 x 247 x 54 mm 12.99 x 9.72 x 2.13 in	6



071102

Estuche con tapa transparente y base con compartimentos fijos de PP verde.

Organizer with transparent lid and base with fixed compartments made of green PP.

Coffret avec couvercle transparent et base avec compartiments fixes en PP vert.



050107



060106



051104



061103



008009



009006



070105



**ESTUCHES
ORGANIZERS
COFFRETS**



014000

Estuche transparente de PP.
Ideal para almacenar y transportar pequeños
objetos y herramientas.

Transparent PP organizer.
Ideal for storing and transporting small items and
tools.

Coffret transparente en PP.
Idéale pour le stockage et le transport de petits
objets et d'outils.



004001



006005



012006



013003

EUROHOLE
WITH EUROHOLE / AVEC EUROHOLE

CÓDIGO CODE	MODELO MODEL MODÈLE	L x A x H MEDIDAS SIZES / MESURES	EMBALAJE / UNIDADES PACKING / UNITS EMBALLAGE / UNITÉS
004001	23-1	160 x 122 x 30 mm 6.30 x 4.80 x 1.18 in	24
006005	25-1	178 x 140 x 34 mm 7.01 x 5.51 x 1.34 in	24
012006	170-7	170 x 114 x 36 mm 6.69 x 4.49 x 1.42 in	12
013003	240-12	240 x 155 x 41 mm 9.45 x 6.10 x 1.61 in	12
014000	300-16	300 x 199 x 46 mm 11.81 x 7.83 x 1.81 in	6

Sus separadores móviles permiten una
organización óptima del interior.

The movable dividers allow for optimal
organisation of the interior.

Les séparateurs mobiles permettent une
organisation optimale de l'intérieur.

CÓDIGO CODE	MODELO MODEL MODÈLE	L x A x H MEDIDAS SIZES / MESURES	EMBALAJE / UNIDADES PACKING / UNITS EMBALLAGE / UNITÉS
011009	500-25	440 x 244 x 49 mm 17.32 x 9.61 x 1.93 in	6

Compatible con las cajas 500 (165009 y 166006) y con trail
box 57, trail box 57 PREMIUM y trail box 58.

Compatible with tool boxes 500 (165009 and 166006) and
trail box 57, trail box 57 PREMIUM and trail box 58.

Compatible avec la boîte 500 (165009 et 166006) et la boîte
trail 57, la boîte trail 57 PREMIUM et la boîte trail 58.

011009





1.1.5. ESTUCHES CON SEPARADORES MÓVILES ORGANIZERS WITH MOBILE DIVIDERS COFFRET À SÉPARATEURS



Mango ergonómico
Ergonomic handle
Manche ergonomique



Doble cierre
Double closure
Double fermeture



Separadores móviles. Compartimentos diseñados para que no se mezclen.
Organiser case with movable dividers.
Coffret à séparateurs amovibles, avec séparateurs.

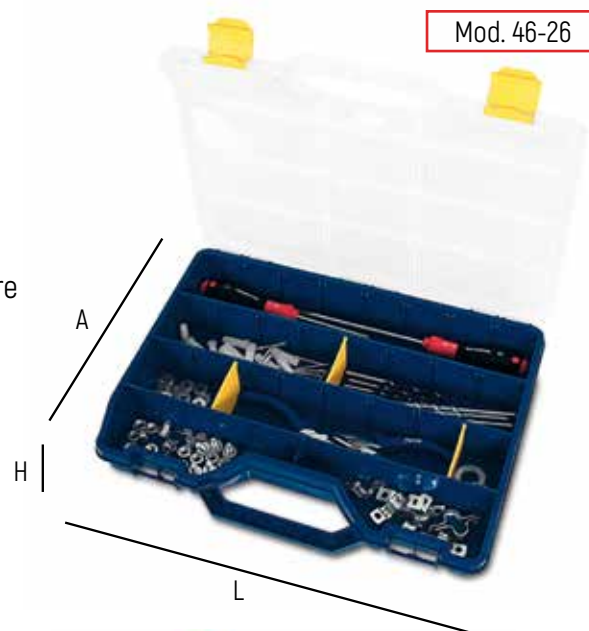

Mod. 46-26



145001



146008



147005



049002*



148002

*Compatible con las cajas 550-B, 550-E, 650-B y 650-E (170003, 171000, 172007, 173004)

*Compatible with tool boxes 550-B, 550-E, 650-B and 650-E (170003, 171000, 172007, 173004)

*Compatible avec les boîtiers 550-B, 550-E, 650-B et 650-E (170003, 171000, 172007, 173004)

CÓDIGO CODE	MODELO MODEL / MODÈLE	L x A x H MEDIDAS SIZES / MESURES	CONTIENE CONTAINED / CONTIENT	MATERIAL MATERIAL / MATÉRIAU	EMBALAJE / UNIDADES PACKING / UNITS EMBALLAGE / UNITÉS
145001	45-26	312 x 238 x 51 mm 12.28 x 9.37 x 2.01 in		PP	6
146008	46-26	378 x 290 x 61 mm 14.88 x 11.42 x 2.40 in		PP	6
147005	47-26	460 x 350 x 81 mm 18.11 x 13.78 x 3.19 in	21 Separadores Dividers / Séparateurs	PP	5
148002	48-26	460 x 350 x 81 mm 18.11 x 13.78 x 3.19 in		PP + tapa PC PP + cover PC PP + couvercle PC	5
049002*	49-16	490 x 250 x 80 mm 19.29 x 9.84 x 3.15 in	12 Separadores Dividers / Séparateurs	PP	5



024009

Estuche de alta calidad fabricado completamente con polipropileno (PP).

High quality organizer made entirely of polypropylene (PP).

Coffret de haute qualité entièrement fabriquée en polypropylène (PP).



020001



021008



022005



023002

CÓDIGO CODE	MODELO MODEL / MODÈLE	L X A X H MEDIDAS SIZES / MESURES	CONTIENE CONTAINED / CONTIENT	EMBALAJE / UNIDADES PACKING / UNITS EMBALLAGE / UNITÉS
020001	20-9	190 x 150 x 42 mm 7.48 x 5.91 x 1.65 in	-	12
021008	21-10	256 x 192 x 42 mm 10.08 x 7.56 x 1.65 in	-	12
022005	22-26	312 x 238 x 51 mm 12.28 x 9.37 x 2.01 in		6
023002	23-26	388 x 290 x 61 mm 15.28 x 11.42 x 2.40 in	21 Separadores Dividers / Séparateurs	6
024009	24-26	460 x 350 x 81 mm 18.11 x 13.78 x 3.19 in		5



1.1.5. ESTUCHES CON CAJONES EXTRAÍBLES ORGANIZERS WITH MOBILE DRAWERS COFFRET À COMPARTIMENTS AMOVIBLES



030000



031007



030406



034008



035005



034404

CÓDIGO CODE	MODELO MODEL MODÈLE	L x A x H MEDIDAS SIZES / MESURES	CONTIENE CONTAINED / CONTIENT	MATERIAL MATERIAL / MATÉRIAU	EMBALAJE / UNIDADES PACKING / UNITS EMBALLAGE / UNITÉS
030000	430/50/50	430 x 370 x 55 mm 16.93 x 14.57 x 2.17 in	Cajones / Drawers / Tiroirs 50 / A50	Base PP Tapa / Cover / Couverture PS Cajones / Drawers / Tiroirs PS	4
031007	430/50/25	430 x 370 x 55 mm 16.93 x 14.57 x 2.17 in	Cajones / Drawers / Tiroirs 10 / A50 10 / B50 5 / C50	Base PP Tapa / Cover / Couverture PS Cajones / Drawers / Tiroirs PS	4
030406	430/50/0	430 x 370 x 55 mm 16.93 x 14.57 x 2.17 in	-	Base PP Tapa / Cover / Couverture PS	4
034008	330/50/32	330 x 247 x 54 mm 12.99 x 9.72 x 2.13 in	Cajones / Drawers / Tiroirs 32 / A50	Base PP Tapa / Cover / Couverture PS Cajones / Drawers / Tiroirs PS	6
035005	330/50/16	330 x 247 x 54 mm 12.99 x 9.72 x 2.13 in	Cajones / Drawers / Tiroirs 8 / A50 4 / B50 4 / C50	Base PP Tapa / Cover / Couverture PS Cajones / Drawers / Tiroirs PS	6
034404	330/50/0	330 x 247 x 54 mm 12.99 x 9.72 x 2.13 in	-	Base PP Tapa / Cover / Couverture PS	6

CAJONES EXTRAÍBLES 50 / REMOVABLE DRAWERS 50 / COMPARTIMENTS AMOVIBLES 50

CÓDIGO CODE	MODELO MODEL / MODÈLE	L x A x H MEDIDAS SIZES / MESURES	MATERIAL MATERIAL / MATÉRIAU	EMBALAJE / UNIDADES PACKING / UNITS EMBALLAGE / UNITÉS
040009	A50	55 x 39 x 47 mm 2.17 x 1.54 x 1.85 in	PS	300
041006	B50	79 x 55 x 47 mm 3.11 x 2.17 x 1.85 in	PS	150
042003	C50	109 x 79 x 47 mm 4.29 x 3.11 x 1.85 in	PS	75





Doble cierre
Double closure
Double fermeture



032004



033001

CÓDIGO CODE	MODELO MODEL / MODÈLE	L x A x H MEDIDAS SIZES / MESURES	CONTIENE CONTAINED / CONTIENT	MATERIAL MATERIAL / MATÉRIAU	EMBALAJE / UNIDADES PACKING / UNITS EMBALLAGE / UNITÉS
032004	430/80/25	430 x 370 x 85 mm 16.93 x 14.57 x 3.35 in	Cajones / Drawers / Tiroirs 25 / B80	Base PP Tapa / Cover / Couvercle PS Cajones / Drawers / Tiroirs PS	4
033001	430/80/13	430 x 370 x 85 mm 16.93 x 14.57 x 3.35 in	Cajones / Drawers / Tiroirs 5 / B80 6 / C80 2 / D80	Base PP Tapa / Cover / Couvercle PS Cajones / Drawers / Tiroirs PS	4

CAJONES EXTRAÍBLES 80 REMOVABLE DRAWERS 80 COMPARTIMENTS AMOVIBLES 80

CÓDIGO CODE	MODELO MODEL / MODÈLE	L x A x H MEDIDAS SIZES / MESURES	MATERIAL MATERIAL / MATÉRIAU	EMBALAJE / UNIDADES PACKING / UNITS EMBALLAGE / UNITÉS
043000	B80	79 x 55 x 76 mm 3.11 x 2.17 x 2.99 in	PS	90
044007	C80	109 x 79 x 76 mm 4.29 x 3.11 x 2.99 in	PS	45
045004	D80	157 x 109 x 76 mm 6.18 x 4.29 x 2.99 in	PS	21



1.2.6. MULTIBOX MULTIBOX MULTIBOX



- **Organización eficiente.**
- **Identificación rápida:** Tapa transparente que facilita la identificación visual del contenido almacenado.
- **Espacio amplio.**
- **Adaptable a múltiples entornos:** Robusto y resistente, ideal para aplicaciones industriales, comerciales o domésticas.
- **Efficient organisation.**
- **Quick identification:** Transparent lid for easy visual identification of stored contents.
- **Ample space.**
- **Adaptable to multiple environments:** Robust and durable, ideal for industrial, commercial or domestic applications.
- **Organisation efficace.**
- **Identification rapide:** Couvercle transparent pour une identification visuelle facile du contenu stocké.
- **Beaucoup d'espace.**
- **Adaptable à de multiples environnements:** Robuste et résistant, idéal pour les applications industrielles, commerciales ou domestiques.



Multibox con 4 estuches con separadores móviles 22

Multibox with 4 organiser cases with mobile dividers 22-26

Multi-box avec 4 casiers à séparateurs amovibles 22-26



Con asa de seguridad antiapertura

Sturdy handle for easy transport

Avec anse résistante pour faciliter le transport



301001

Con función apilable para una mayor organización
Stackable for greater organisation
Avec fonction empilable pour une meilleure organisation



302008



303005



302503



303500

CÓDIGO CODE	MODELO MODEL MODÈLE	L x A x H MEDIDAS SIZES / MESURES	CONTIENE CONTAINED / CONTIENT	MATERIAL MATERIAL / MATÉRIAU	EMBAJAJE / UNIDADES PACKING / UNITS EMBALLAGE / UNITÉS
301001	Multibox nº 1	335 x 250 x 275 mm 13.19 x 9.84 x 10.83 in	Módulo + 4 estuches (22-26) + asa Module + 4 organizers (22-26) + handle Module + 4 coffres (22-26) + poignée	PP	2
302008	Multibox nº 2	447 x 314 x 360 mm 17.60 x 12.36 x 14.17 in	Módulo + 4 estuches (23-26) Module + 4 organizers (23-26) Module + 4 coffres (23-26)	PP	2
303005	Multibox nº 3	530 x 376 x 430 mm 20.87 x 14.80 x 16.93 in	Módulo + 4 estuches (24-26) Module + 4 organizers (24-26) Module + 4 coffres (24-26)	PP	1
302503	Multibox nº 2 L	447 x 314 x 360 mm 17.60 x 12.36 x 14.17 in	Módulo + 4 estuches (46-26) Module + 4 organizers (46-26) Module + 4 coffres (46-26)	PP	2
303500	Multibox nº 3 L	530 x 376 x 430 mm 20.87 x 14.80 x 16.93 in	Módulo + 4 estuches (47-26) Module + 4 organizers (47-26) Module + 4 coffres (47-26)	PP	1

1.1.7. MALETAS HERRAMIENTAS ELÉCTRICAS CASES FOR ELECTRICAL TOOLS MALLETTES POUR OUTILLAGE ÉLECTRIQUE



140006



141003



142000

CÓDIGO CODE	MODELO MODEL MODÈLE	L x A x H MEDIDAS SIZES / MESURES	CONTIENE CONTAINED / CONTIENT	MATERIAL MATERIAL MATÉRIAU	COLOR COLOUR COULEU	EMBALAJE / UNIDADES PACKING / UNITS EMBALLAGE / UNITÉS
140006	40	385 x 330 x 130 mm 15.16 x 12.99 x 5.12 in	Vacio / Empty / Vide	PP	●	7
141003	41	385 x 330 x 130 mm 15.16 x 12.99 x 5.12 in	1 Estuche / Box / Coffret	PP	⊙ ● caja / tool box / boîte ● estuche/organizer/coffret	7
142000	42	385 x 330 x 130 mm 15.16 x 12.99 x 5.12 in	1 Bandeja / Tray / Panier porte-outils	PP	● caja / tool box / boîte ● bandeja / tray / panier porte-outils	7



MALETAS
CASES
MALLETES

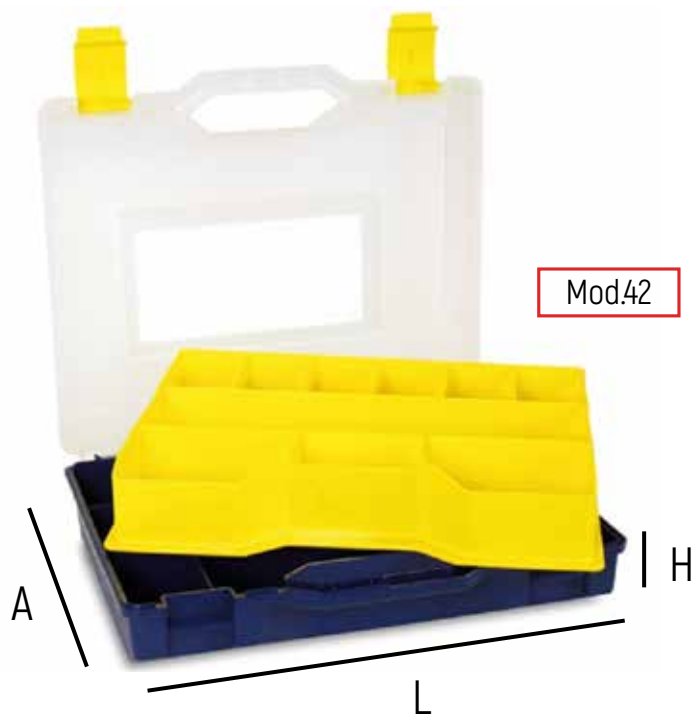

Mod.42



Mod.40

Protección para contenido en todos los modelos.
All models have content protection.
Protection pour le contenu dans tous les modèles.



143007



144004

CÓDIGO CODE	MODELO MODEL MODÈLE	L x A x H MEDIDAS SIZES / MESURES	CONTIENE CONTAINED / CONTIENT	MATERIAL MATERIAL MATÉRIAU	COLOR COLOUR COULEU	EMBALAJE / UNIDADES PACKING / UNITS EMBALLAGE / UNITÉS
143007	43	401 x 352 x 156 mm 15.79 x 13.86 x 6.14 in	20 Separadores / Dividers / Séparateurs	PP	●	6
144004	44	430 x 370 x 140 mm 16.93 x 14.57 x 5.51 in	Vacío / Empty / Vide	PP	●	4

1.1.8.BASIC LINE BASIC LINE BASIC LINE



022555

023552

024559

301551

CÓDIGO CODE	MODELO MODEL MODÈLE	L x A x H MEDIDAS SIZES / MESURES	CONTIENE CONTAINED / CONTIENT	MATERIAL MATERIAL MATÉRIAU	EMBALAJE / UNIDADES PACKING / UNITS EMBALLAGE / UNITÉS
022555	AccessoryBox 01	312 x 238 x 51 mm 12.28 x 9.37 x 2.01 in	21 Separadores / Dividers / Séparateurs	PP	6
023552	AccessoryBox 02	388 x 290 x 61 mm 15.28 x 11.42 x 2.40 in	21 Separadores / Dividers / Séparateurs	PP	6
024559	AccessoryBox 03	460 x 350 x 81 mm 18.11 x 13.78 x 3.19 in	21 Separadores / Dividers / Séparateurs	PP	5
301551	Multibox n°1 BL	335 x 250 x 275 mm 13.19 x 9.84 x 10.83 in	Módulo + 4 estuches 22 + asa Piece + 4 organizers 22 + handle Module + 4 coffrett 22 + poignée	PP	2



BASIC LINE



110559



112553



115554



998683

CÓDIGO CODE	MODELO MODEL MODÈLE	L x A x H MEDIDAS SIZES / MESURES	CONTIENE CONTAINED / CONTIENT	MATERIAL MATERIAL / MATÉRIAU	EMBALAJE / UNIDADES PACKING / UNITS EMBALLAGE / UNITÉS
110559	ToolBox 12"	290 x 170 x 127 mm 11.42 x 6.69 x 5.00 in	1 Bandeja / Tray / Panier porte-outils	PP	10
112553	ToolBox 16"	400 x 217 x 166 mm 15.75 x 8.54 x 6.54 in	1 Bandeja / Tray / Panier porte-outils	PP	6
115554	ToolBox 20"	500 x 258 x 255 mm 19.69 x 10.16 x 10.04 in	1 Bandeja / Tray / Panier porte-outils	PP 	3
998683	KIT Cajas basic line	500 x 258 x 255 mm 19.69 x 10.16 x 10.04 in	ToolBox 12" (110559) + ToolBox 16" (112553) + ToolBox 20" (115554)	PP	3
998553	Box palet	-	24 uds. de 998683 24 units of 998683 24 unités de 998683	PP	24 uds. por palet 24 units per pallet 24 unités par palette

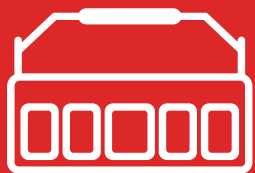

11.9. TEXTIL: BOLSAS, MOCHILAS Y CINTURONES TEXTILES: BAGS, BACKPACKS AND BELTS TEXTILE : SACS, SACS À DOS ET CEINTURES



080005



082009



097003

CÓDIGO CODE	MODELO MODEL MODÈLE	L x A x H MEDIDAS SIZES / MESURES	MATERIAL MATERIAL MATÉRIAU	EMBALAJE / UNIDADES PACKING / UNITS EMBALLAGE / UNITÉS
080005	Bolsa Herramientas BN-1 (13") Tool Bag BN-1(13") Sacs à outils BN-1(13")	345 x 220 x 225 mm 13.58 × 8.66 × 8.86 in	Poliéster 600D Polyester 600D	6
082009	Bolsa Herramientas BN-3 (18") Tool Bag BN-3(18") Sacs à outils BN-3(18")	455 x 250 x 265 mm 17.91 × 9.84 × 10.43 in	Bolsa Poliéster 900D / Fondo Polietileno Polyester 900D Bag / Base Polytene Polyester 900D Sac / Fond Polyéthylène	6
097003	Bolsa Herramientas BN-7 (20") Tool Bag BN-7 (20") Sacs à outils BN-7 (20")	500 x 220 x 290 mm 19.69 × 8.66 × 11.42 in	Poliéster 900D Polyester 900D	6

Tayg

TEXTIL
TEXTILES
TEXTILE



098604



097607

CÓDIGO CODE	MODELO MODEL MODÈLE	L x A x H MEDIDAS SIZES / MESURES	CAPACIDAD CAPACITY / CAPACITÉ	MATERIAL MATERIAL / MATÉRIAU	EMBALAJE / UNIDADES PACKING / UNITS EMBALLAGE / UNITÉS
098604	MN-2	380 x 223 x 510 mm 14.96 x 8.78 x 20.08 in	33L	Poliéster 600D-900D Polyester 600D-900D	2
097607	MN-1	390 x 190 x 490 mm 15.35 x 7.48 x 19.29 in	30L	Poliéster 600D Polyester 600D	2

1.1.9. TEXTIL: BOLSAS, MOCHILAS Y CINTURONES TEXTILES: BAGS, BACKPACKS AND BELTS TEXTILE : SACS, SACS À DOS ET CEINTURES



089602



090608



091605



092602

CÓDIGO
CODE

MODELO
MODEL
MODÈLE

MATERIAL
MATERIAL / MATÉRIAU

EMBALAJE / UNIDADES
PACKING / UNITS
EMBALLAGE / UNITÉS

089602	Cinturón herramientas simple Simple tool pouch Ceinture porte-outils simple	Poliéster 600D Polyester 600D	10
090608	Cinturón herramientas doble Double tool pouch Ceinture porte-outils double	Poliéster 600D Polyester 600D	6
091605	Cinturón herramientas simple-profesional Professional simple tool pouch Ceinture porte-outils simple professionnelle	Poliéster 900D Polyester 900D	10
092602	Cinturón herramientas doble-profesional Professional double tool pouch Ceinture porte-outils double professionnelle	Poliéster 900D Polyester 900D	6

PROFESIONAL

Tayg

TEXTIL
TEXTILES
TEXTILE



086601



087608



083600



084607



082603



081606

CÓDIGO CODE	MODELO MODEL MODÈLE	MATERIAL MATERIAL / MATÉRIAU	EMBALAJE / UNIDADES PACKING / UNITS EMBALLAGE / UNITÉS
086601	Cinturón soporte simple Simple hold belt Ceinture support simple	Cuero natural Natural leather / Cuir naturel	10
087608	Cinturón soporte profesional Professional hold belt Ceinture support professionnel	Cuero natural Natural leather / Cuir naturel	10
083600	Soporte electricista Electrician holder / Support electricien	Cuero natural Natural leather / Cuir naturel	10
084607	Guarda tijeras podar Pruning shears holder / Support sécateurs	Cuero natural Natural leather / Cuir naturel	10
082603	Soporte cutter Cutter holde / Support cutter	Cuero natural Natural leather / Cuir naturel	10
081606	Soporte martillo Hammer holder / Support marteau	Cuero natural Natural leather / Cuir naturel	10



1.2

ORDENACIÓN ARRANGEMENT RANGEMENT

1.2.1. GAVETAS APILABLES STACKABLE DRAWERS / BAC À BEC EMPILABLE	50
1.2.2. GAVETAS APILABLES ENCAJABLES STACKABLE NESTABLE DRAWERS / BAC À BEC EMPILABLE ET EMBOÎTABLES	55
1.2.3. GAVETAS APILABLES PLEGABLES STACKABLE FOLDING DRAWER / BAC À BEC PLIABLE EMPILABLE	56
1.2.4. EURO-CAJAS DUTY BOXES / BOÎTES DE SERVICE	58
1.2.5. CONTENEDOR APILABLE ENCAJABLE STACKABLE CABINET / BAC EMPILABLE EMBOÎTABLE	60
1.2.6. CONTENEDORES BASCULANTES CABINET WITH TILTABLE DRAWERS / BACS BASCULANTS	61
1.2.7. ESTANTERÍA PLÁSTICO PLASTIC SHELVING / SET ÉTAGÈRE PLASTIQUE	62
1.2.8. ESTANTERÍA METÁLICA METAL SHELVING / ÉTAGÈRES MÉTALLIQUES	64
1.2.9. ESTANTERÍAS MODELO CAIRO SHELVES CAIRO MODEL / ÉTAGÈRE MODÈLE CAIRO	68
1.2.10. MÓDULOS METÁLICOS METAL STACKABLE MODULES / MODULES MÉTALLIQUES	70
1.2.11. CLASIFICADORES APILABLES STACKABLE FILING CABINETS / CLASSIFICATEURS EMPILABLES	71
1.2.12. CONTENEDORES CAJONES Y MÓDULOS APILABLES CONTAINERS STACKABLE DRAWERS AND MODULES / CONTENEURS TIROIRS ET MODULES EMPILABLES	72



GAVETAS
DRAWERS
BAC À BEC

1.2.1. GAVETAS APILABLES STACKABLE DRAWERS BAC À BEC EMPILABLE



251023



252020



253027



254024



255021

CÓDIGO CODE	MODELO MODEL MODÈLE	L x A x H MEDIDAS SIZES / MESURES	CAPACIDAD (LITROS) CAPACITY (LITRES) CAPACITÉ (LITRES)	MATERIAL MATERIAL MATÉRIAU	EMBALAJE / UNIDADES PACKING / UNITS EMBALLAGE / UNITÉS
251023 251108 251344	51	170 x 100 x 80 mm 6.69 x 3.94 x 3.15 in	0,8	PP	24
252020 252105 252341	52	236 x 160 x 130 mm 9.29 x 6.30 x 5.12 in	3,2	PP	15
253027 253102 253348	53	336 x 160 x 130 mm 13.23 x 6.30 x 5.12 in	4,8	PP	10
254024 254109 254345	54	336 x 216 x 155 mm 13.23 x 8.50 x 6.10 in	7,7	PP	12
255021 255106 255342	55	336 x 216 x 200 mm 13.23 x 8.50 x 7.87 in	10,1	PP	8



GAVETAS
DRAWERS
BAC À BEC

COLORES: AZUL / ROJO / TRANSPARENTE
COLORS: BLUE / RED / TRANSPARENT
COULEURS: BLEU / ROUGE / TRANSPARENT

Color transparente bajo pedido, consultar.
Transparent colour available on request, consult.
Couleur transparente sur demande, nous consulter.

Etiquetas descargables en la web
Downloadable labels on the web
Étiquettes téléchargeables sur le site web

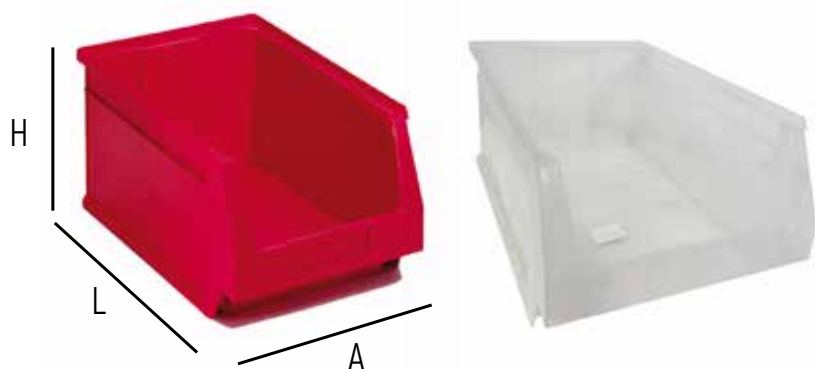

*Modelo compatible con euroroller.
*Model compatible with euroroller
*Modèle compatible avec euroroller



256028



258022



259029



260025

CÓDIGO CODE	MODELO MODEL MODÈLE	L x A x H MEDIDAS SIZES / MESURES	CAPACIDAD (LITROS) CAPACITY (LITRES) CAPACITÉ (LITRES)	MATERIAL MATERIAL MATÉRIAU	EMBALAJE / UNIDADES PACKING / UNITS EMBALLAGE / UNITÉS
256028 256103 256349	56	420 x 270 x 175 mm 16.54 x 10.63 x 6.89 in	13,9	PP	8
258022 258107 258343	58	500 x 303 x 200 mm 19.69 x 11.93 x 7.87 in	22,2	PP	12
259029 259104 259340	59	500 x 303 x 300 mm 19.69 x 11.93 x 11.81 in	34	PP	6
260025 260100 260346	60*	600 x 400 x 300 mm 23.62 x 15.75 x 11.81 in	51,3	PP	6

GAVETAS
DRAWERS
BAC À BEC

1.2.1. GAVETAS APILABLES STACKABLE DRAWERS BAC À BEC EMPILABLE



251061

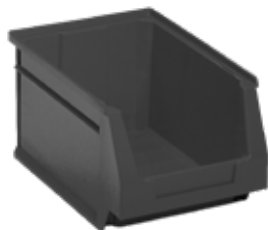

252068



253065



254062



255069

CÓDIGO CODE	MODELO MODEL MODÈLE	L x A x H MEDIDAS SIZES / MESURES	CAPACIDAD (LITROS) CAPACITY (LITRES) CAPACITÉ (LITRES)	MATERIAL MATERIAL MATÉRIAU	EMBALAJE / UNIDADES PACKING / UNITS EMBALLAGE / UNITÉS
251061 251115 251283 251269	51	170 x 100 x 80 mm 6.69 x 3.94 x 3.15 in	0,8	PP	24
252068 252112 252280 252266	52	236 x 160 x 130 mm 9.29 x 6.30 x 5.12 in	3,2	PP	15
253065 253119 253287 253263	53	336 x 160 x 130 mm 13.23 x 6.30 x 5.12 in	4,8	PP	10
254062 254116 254284 254260	54	336 x 216 x 155 mm 13.23 x 8.50 x 6.10 in	7,7	PP	12
255069 255113 255281 255267	55	336 x 216 x 200 mm 13.23 x 8.50 x 7.87 in	10,1	PP	8



GAVETAS
DRAWERS
BAC À BEC

Etiquetas descargables en la web
Downloadable labels on the web
Étiquettes téléchargeables sur le site web



COLORES: AZUL / TURQUESA / VERDE / GRIS INDUSTRIAL
COLORS: BLUE / TURQUOISE / GREEN / INDUSTRIAL GREY
COULEURS: BLEU / TURQUOISE / VERT / GRIS INDUSTRIEL

Color verde bajo pedido, consultar.
Green colour available on request, consult.
Couleur verte sur demande, nous consulter.

*Modelo compatible con euroroller.

*Model compatible with euroroller

*Modèle compatible avec euroroller



256066



258060



259067



260063

CÓDIGO CODE	MODELO MODEL MODÈLE	L x A x H MEDIDAS SIZES / MESURES	CAPACIDAD (LITROS) CAPACITY (LITRES) CAPACITÉ (LITRES)	MATERIAL MATERIAL MATÉRIAU	EMBALAJE / UNIDADES PACKING / UNITS EMBALLAGE / UNITÉS
256066 256110 256288 256264	56	420 x 270 x 175 mm 16.54 x 10.63 x 6.89 in	13,9	PP	8
258060 258114 258282 258268	58	500 x 303 x 200 mm 19.69 x 11.93 x 7.87 in	22,2	PP	12
259067 259111 259289 259265	59	500 x 303 x 300 mm 19.69 x 11.93 x 11.81 in	34	PP	6
260063 260117 260285 260261	60*	600 x 400 x 300 mm 23.62 x 15.75 x 11.81 in	51,3	PP	6

1.2.1. GAVETAS APILABLES STACKABLE DRAWERS BAC À BEC EMPILABLE

Etiquetas descargables en la web
Downloadable labels on the web
Étiquettes téléchargeables sur le site web



250903

251900

CÓDIGO CODE	MODELO MODEL MODÈLE	L x A x H MEDIDAS SIZES / MESURES	CONTIENE CONTAINED CONTIENT	MATERIAL MATERIAL MATÉRIAU	EMBALAJE / UNIDADES PACKING / UNITS EMBALLAGE / UNITÉS
250903	Kit Colgar G-50 Hanging kit G-50 Kit a accrocher G-50	91 x 520 x 53 mm 3.58 x 20.47 x 2.09 in	5 Gavetas n°50 / 1 Colgador 5 Drawers n°50 / 1 Hanger 5 Bacs n°50 / 1 Rail	Gaveta PP / Colgador PS Drawer PP / Hanger PS Bac PP / Rail PS	10
251900	Kit Colgar G-51 Hanging kit G-51 Kit a accrocher G-51	170 x 520 x 80 mm 6.69 x 20.47 x 3.15 in	5 Gavetas n°51 / 1 Colgador 5 Drawers n°51 / 1 Hanger 5 Bacs n°51 / 1 Rail	Gaveta PP / Colgador PS Drawer PP / Hanger PS Bac PP / Rail PS	10

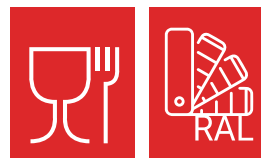

1.2.2. GAVETAS APILABLES ENCAJABLES STACKABLE NESTABLE DRAWERS BAC À BEC EMPILABLE ET EMBOÎTABLES

GAVETAS
DRAWERS
BAC À BEC



NEW









CÓDIGO CODE	MODELO MODEL MODÈLE	L x A x H MEDIDAS SIZES / MESURES	CAPACIDAD (LITROS) CAPACITY (LITRES) CAPACITÉ (LITRES)	MATERIAL MATERIAL MATÉRIAU	EMBALAJE / UNIDADES PACKING / UNITS EMBALLAGE / UNITÉS
 241901	Kit 6 gavetas 51E colgar	170 x 107 x 80 mm 6.69 x 4.21 x 3.15 in	0.8	PP	10
 242908	Kit4 gavetas 52E colgar	220 x 175 x 130 mm 8.66 x 6.89 x 5.12 in	3.2	PP	10

*Bajo pedido, consultar.
Available on request, consult.
Sur demande, nous consulter.

COLORES: AZUL / ROJO / GRIS INDUSTRIAL / AZUL INDUSTRIAL
COLORS: BLUE / RED / INDUSTRIAL GREY / INDUSTRIAL BLUE
COULEURS: BLEU / ROUGE / GRIS INDUSTRIEL / BLEU INDUSTRIEL



CÓDIGO CODE	MODELO MODEL MODÈLE	L x A x H MEDIDAS SIZES / MESURES	CAPACIDAD (LITROS) CAPACITY (LITRES) CAPACITÉ (LITRES)	MATERIAL MATERIAL MATÉRIAU	EMBALAJE / UNIDADES PACKING / UNITS EMBALLAGE / UNITÉS
 241024*  241109* 241062 (INDUSTRIAL) 241116 (INDUSTRIAL)	51E	170 x 107 x 80 mm 6.69 x 4.21 x 3.15 in	0.8	PP	24
 242021*  242106* 242069 (INDUSTRIAL) 242113 (INDUSTRIAL)	52E	220 x 175 x 130 mm 8.66 x 6.89 x 5.12 in	3.2	PP	14
 244025*  244100* 244063 (INDUSTRIAL) 244117 (INDUSTRIAL)	54E	335 x 235 x 160 mm 13.19 x 9.25 x 6.30 in	4.2	PP	12

GAVETAS
DRAWERS
BAC À BEC

1.2.3. GAVETAS APILABLES PLEGABLES STACKABLE FOLDING DRAWER BAC À BEC PLIABLE EMPILABLE



Etiquetas descargables en la web

Downloadable labels on the web

Étiquettes téléchargeables sur le site web

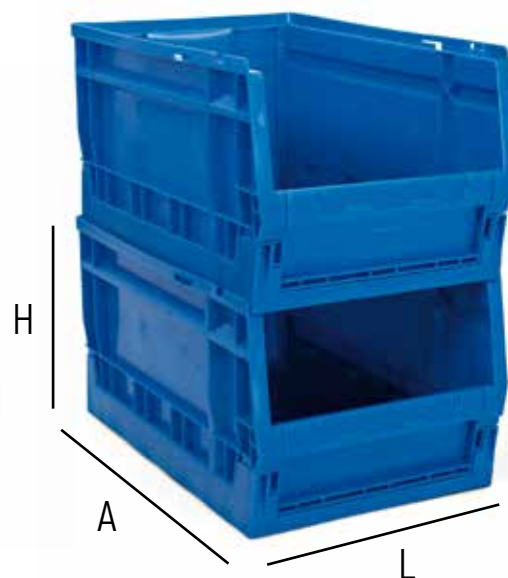

COLORES: AZUL / TRANSPARENTE
COLORS: BLUE / TRANSPARENT
COULEURS: BLEU / TRANSPARENT

*Bajo pedido, consultar.
Available on request, consult.
Sur demande, nous consulter.



204029



206023



209024



210020

CÓDIGO CODE	MODELO MODEL MODÈLE	L x A x H MEDIDAS SIZES / MESURES	CAPACIDAD (LITROS) CAPACITY (LITRES) CAPACITÉ (LITRES)	MATERIAL MATERIAL MATÉRIAU	EMBALAJE / UNIDADES PACKING / UNITS EMBALLAGE / UNITÉS
204029 204340*	54P	336 x 216 x 175 mm 13.23 x 8.50 x 6.89 in	8,5	PP	11
206023 206344*	56P	420 x 270 x 200 mm 16.54 x 10.63 x 7.87 in	15	PP	11
209024 209345*	59P	500 x 303 x 275 mm 19.69 x 11.93 x 10.83 in	30	PP	8
210020 210341*	60P	600 x 400 x 325 mm 23.62 x 15.75 x 12.80 in	55	PP	6



GAVETAS
DRAWERS
BAC À BEC

Etiquetas descargables en la web
Downloadable labels on the web
Étiquettes téléchargeables sur le site web



202346



202025

CÓDIGO CODE	MODELO MODEL MODÈLE	L x A x H MEDIDAS SIZES / MESURES	CONTIENE CONTAINED CONTIENT	MATERIAL MATERIAL MATÉRIAU	EMBALAJE / UNIDADES PACKING / UNITS EMBALLAGE / UNITÉS
202025 202346	52P	236 x 160 x 130 mm 9.29 x 6.30 x 5.12 in	1 Kit = 5 Gavetas flejadas 1 Kit = 5 Strapped bin boxes 1 Set = 5 Bacs à bec dépliés	PP	8 Kits = 40 U
203022 203343	53P	336 x 160 x 130 mm 13.23 x 6.30 x 5.12 in	1 Kit = 5 Gavetas flejadas 1 Kit = 5 Strapped bin boxes 1 Set = 5 Bacs à bec dépliés	PP	8 Kits = 40 U

1.2.4. EURO-CAJAS DUTY BOXES BOÎTES DE SERVICE

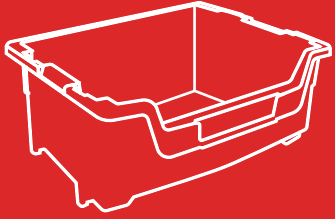

265006



266003



267000



267994

CÓDIGO CODE	MODELO MODEL MODÈLE	L x A x H MEDIDAS SIZES / MESURES	CAPACIDAD (LITROS) CAPACITY (LITRES) CAPACITÉ (LITRES)	PESO WEIGHT / POIDS	MATERIAL MATERIAL MATÉRIAU	EMBALAJE / UNIDADES PACKING / UNITS EMBALLAGE / UNITÉS
265006	6424-T	600 x 400 x 240 mm 23.62 x 15.75 x 9.45 in	39	2,5 kg	PP	6 Retráctil / 56 Palet 6 Retractable / 56 Pallet 6 Emballage / 56 Palette
266003 266065 ✗	6434-T	600 x 400 x 340 mm 23.62 x 15.75 x 13.39 in	58	3 kg	PP	6 Retráctil / 48 Palet 6 Retractable / 48 Pallet 6 Emballage / 48 Palette
267000 267062 ✗	6444-T	600 x 400 x 440 mm 23.62 x 15.75 x 17.32 in	75	3,7 kg	PP	6 Retráctil / 32 Palet 6 Retractable / 32 Pallet 6 Emballage / 32 Palette
267994	Euroroller	615 x 415 x 49mm 24.21 x 16.34 x 1.93 in	250 kg	3,9 kg	PP reforzado PP reinforced PP renforcé	5

HYBRID BOX

CÓDIGO CODE	MODELO MODEL MODÈLE
269004	Contenedor palet plegable plástico HDPE Foldable pallet container HDPE plastic Conteneur palette pliable en plastique HDPE 1200x12000x980mm

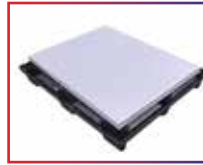
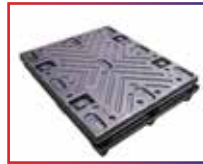

269004

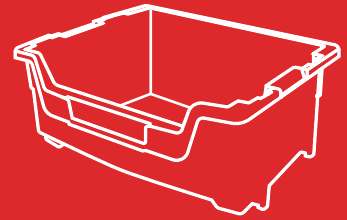

261008



262296



263002



264290



299001

CÓDIGO CODE	MODELO MODEL MODÈLE	L x A x H MEDIDAS SIZES / MESURES	CAPACIDAD (LITROS) CAPACITY (LITRES) CAPACITÉ (LITRES)	MATERIAL MATERIAL MATÉRIAU	EMBALAJE / UNDS PACKING / UNITS EMBALLAGE / UNITÉS	EMBALAJE / UNIDADES PACKING / UNITS EMBALLAGE / UNITÉS
261008 261299	6415	600 x 400 x 150 mm 23.62 x 15.75 x 5.91 in	22	1,23 kg	PP	6 Retractable / 92 Palet 6 Retractable / 92 Pallet 6 Emballage / 92 Palette
262005 262296	6420	600 x 400 x 200 mm 23.62 x 15.75 x 7.87 in	34	1,62 kg	PP	6 Retractable / 64 Palet 6 Retractable / 64 Pallet 6 Emballage / 64 Palette
263002 263293	6430	600 x 400 x 300 mm 23.62 x 15.75 x 11.81 in	51	2,16 kg	PP	6 Retractable / 48 Palet 6 Retractable / 48 Pallet 6 Emballage / 48 Palette
264009 264290	6440	600 x 400 x 400 mm 23.62 x 15.75 x 15.75 in	69	2,74 kg	PP	6 Retractable / 32 Palet 6 Retractable / 32 Pallet 6 Emballage / 32 Palette
299001 299292	6400	600 x 405 x 29 mm 23.62 x 15.94 x 1.14 in	Tapa - Cover - tapa	0,65 kg	PP	6 Retractable 6 Retractable 6 paquet d'emballage

CONTENEDOR
CABINET
BAC

1.2.5. CONTENEDOR APILABLE ENCAJABLE STACKABLE CABINET BAC EMPILABLE EMBOÎTABLE



Etiquetas descargables en la web
Downloadable labels on the web
Étiquettes téléchargeables sur le site web



268021



268069

CÓDIGO
CODE

MODELO
MODEL
MODÈLE

L x A x H
MEDIDAS
SIZES / MESURES

CAPACIDAD (LITROS)
CAPACITY (LITRES)
CAPACITÉ (LITRES)

MATERIAL
MATERIAL
MATÉRIAU

EMBALAJE / UNIDADES
PACKING / UNITS
EMBALLAGE / UNITÉS

268021
268069

5040

395 x 500 x 320 mm
15.55 x 19.69 x 12.60 in

50

PP

7

1.2.6. CONTENEDORES BASCULANTES CABINET WITH TILTABLE DRAWERS BACS BASCULANTS

CONTENEDOR
CABINET
BAC

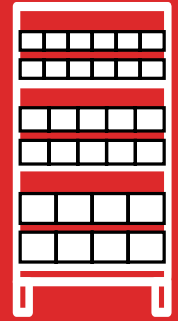

343001	344008
CÓDIGO CODE	MODELO MODEL / MODÈLE

343001	Varilla cierre / Closing rod / Tige étroite
344008	10 tornillos y arandelas 10 screws and washers 10 vis et rondelles

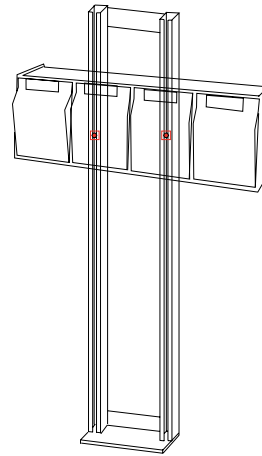

CÓDIGO CODE	MEDIDAS SIZES / MESURES
342004	177 cm



342004



333064	334061	335068	336065	339066
--------	--------	--------	--------	--------

CÓDIGO CODE	MODELO MODEL MODÈLE	L x A x H MEDIDAS SIZES / MESURES	MATERIAL MATERIAL MATÉRIAU	CONTIENE CONTAINED CONTIENT	EMBALAJE / UNDS PACKING / UNITS EMBALLAGE / UNITÉS
333064	3	600 x 196 x 241 mm 23.62 x 7.72 x 9.49 in	PS	No contiene tornillos Doesn't contain screws Ne contient pas de vis	4
334061	4	600 x 168 x 206 mm 23.62 x 6.61 x 8.11 in	PS	No contiene tornillos Doesn't contain screws Ne contient pas de vis	6
335068	5	600 x 133 x 165 mm 23.62 x 5.24 x 6.50 in	PS	No contiene tornillos Doesn't contain screws Ne contient pas de vis	6
336065	6	600 x 92 x 114 mm 23.62 x 3.62 x 4.49 in	PS	No contiene tornillos Doesn't contain screws Ne contient pas de vis	12
339066	9	600 x 63 x 81 mm 23.62 x 2.48 x 3.19 in	PS	No contiene tornillos Doesn't contain screws Ne contient pas de vis	12



1.2.7 ESTANTERÍA PLÁSTICO PLASTIC SHELVING ÉTAGÈRE EN PLASTIQUE



228001



227004



226007



225000

CÓDIGO CODE	MODELO MODEL MODÈLE	L x A x H MEDIDAS SIZES / MESURES	KG POR ESTANTE KG PER SHELF KG PAR ÉTAGÈRE	MATERIAL MATERIAL MATÉRIAU	CONTIENE CONTAINED / CONTIENT	EMBAJAJE / UNIDADES PACKING / UNITS EMBALLAGE / UNITÉS
228001	634	600 x 300 x 1370 mm 23.62 x 11.81 x 53.94 in	30 Kg	Resina PP PP Resin PP résine	4 Bandejas, 12 Puntales, 4 Tapones, 4 Pies, 2 Soportes estantería 4 Trays, 12 Studs, 4 Caps, 4 Feet, 2 Shelving supports 4 Rayons, 12 Montants, 4 Bouchons, 4 Pieds, 2 Supports étagère	1
227004	635	600 x 300 x 1800 mm 23.62 x 11.81 x 70.87 in	30 Kg	Resina PP PP Resin PP résine	5 Bandejas, 16 Puntales, 4 Tapones, 4 Pies, 2 Soportes estantería 5 Trays, 16 Studs, 4 Caps, 4 Feet, 2 Shelving supports 5 Rayons, 16 Montants, 4 Bouchons, 4 Pieds, 2 Supports étagère	1
226007	744	700 x 400 x 1366 mm 27.56 x 15.75 x 53.78 in	40 Kg	Resina PP PP Resin PP résine	4 Bandejas, 12 Puntales, 16 Casquillos reguladores, 4 Tapones, 4 Pies, 2 Soportes estantería 4 Trays, 12 Studs, 16 Regulating bushings, 4 Caps, 4 Feet, 2 Shelving supports 4 Rayons, 12 Montants, 16 Renforts de niveau, 4 Bouchons, 4 Pieds, 2 Supports étagère	1
225000	745	700 x 400 x 1800 mm 27.56 x 15.75 x 70.87 in	40 Kg	Resina PP PP Resin PP résine	5 Bandejas, 16 Puntales, 20 Casquillos reguladores, 6 Tapones, 6 Pies, 3 Soportes estantería 5 Trays, 16 Studs, 20 Regulating bushings, 6 Caps, 6 Feet, 3 Shelving supports 5 Rayons, 16 Montants, 20 Renforts de niveau, 6 Bouchons, 6 Pieds, 3 Supports étagère	1



ESTANTERÍA
SHELVING
ÉTAGÈRE

Instrucciones de montaje
Assembly instructions
Instructions de montage

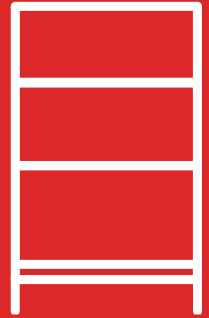

220005



CÓDIGO
CODE

MODELO
MODEL
MODÈLE

L x A x H
MEDIDAS
SIZES / MESURES

KG POR ESTANTE
KG PER SHELF
KG PAR ÉTAGÈRE

MATERIAL
MATERIAL
MATÉRIAU

CONTIENE
CONTAINED / CONTIENT

EMBAJAJE / UNIDADES
PACKING / UNITS
EMBALLAGE / UNITÉS

220005

945

900 x 400 x 1800 mm
35.43 x 15.75 x 70.87 in

40 Kg

Resina PP
PP Resin
PP résine

5 Bandejas, 16 Puntales, 20 Casquillos reguladores, 6 Tapones, 6 Pies, 3 Soportes estantería
5 Trays, 16 Studs, 20 Regulating bushings, 6 Caps, 6 Feet, 3 Shelving supports
5 Rayons, 16 Montants, 20 Renforts de niveau, 6 Bouchons, 6 Pieds, 3 Supports étagère

1

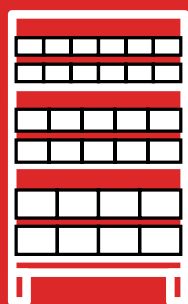

1.2.8. ESTANTERÍA METÁLICA METAL SHELVING ÉTAGÈRE EN MÉTAL

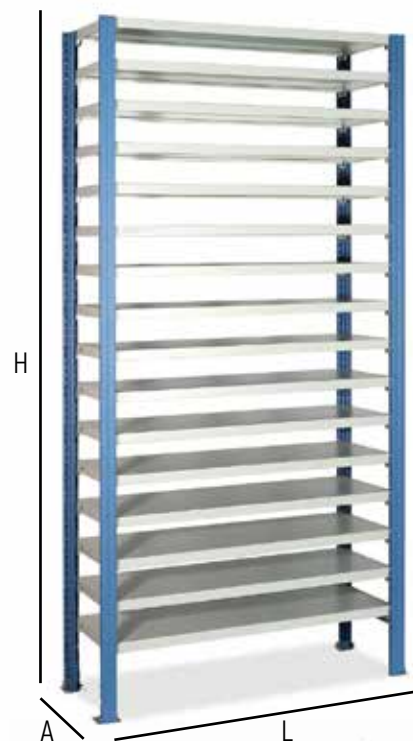

CÓDIGO CODE	MODELO MODEL / MODÈLE	L X A X H MEDIDAS SIZES / MESURES	CONTIENE CONTAINED / CONTIENT
398001	300	1030 x 337 x 2050 mm 40.55 x 13.27 x 80.71 in	4 Puntales / 16 Bandejas 300 / Acc. 16 Bandejas 300 4 Studs / 16 Trays 300 / Acc. 16 Trays 300 4 Montants / 16 Rayons 300 / Acc. 16 rayons 300
399008	400	1030 x 437 x 2050 mm 40.55 x 17.20 x 80.71 in	4 Puntales / 16 Bandejas 400 / Acc. 16 Bandejas 400 4 Studs / 16 Trays 400 / Acc. 16 Trays 400 4 Montants / 16 Rayons 400 / Acc. 16 rayons 400

CÓDIGO CODE	MODELO MODEL / MODÈLE	L X A X H MEDIDAS SIZES / MESURES	CONTIENE CONTAINED / CONTIENT
398308	Kit estantería 301 Shelving kit 301 Set étagères 301	1030 x 337 x 2050 mm 40.55 x 13.27 x 80.71 in	1 Estantería 300 (16 Bandejas) / 120 Cajones 301 / 18 bolsas de 20 Separadores 01 1 Shelving 300 (16 Trays) / 120 Drawers 301 / 18 bags of 20 dividers 01 1 étagères 300 (16 Rayons) / 120 Tiroirs 301 / 18 sacs 20 séparateurs 01
399305	Kit estantería 401 Shelving kit 401 Set étagères 401	1030 x 437 x 2050 mm 40.55 x 17.20 x 80.71 in	1 Estantería 400 (16 Bandejas) / 120 Cajones 401 / 30 bolsas de 20 Separadores 01 1 Shelving 400 (16 Trays) / 120 Drawers 401 / 30 bags of 20 dividers 01 1 étagères 400 (16 Rayons) / 120 Tiroirs 401 / 30 sacs 20 séparateurs 01

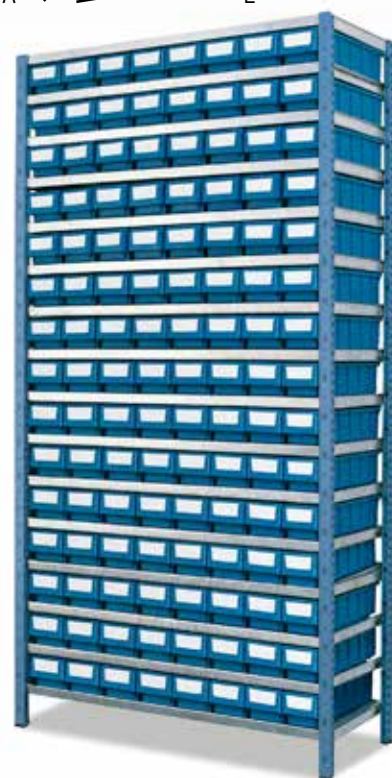

CÓDIGO CODE	MODELO MODEL / MODÈLE	L X A X H MEDIDAS SIZES / MESURES	CONTIENE CONTAINED / CONTIENT
398315	Kit estantería 302 Shelving kit 302 Set étagères 302	1030 x 337 x 2050 mm 40.55 x 13.27 x 80.71 in	1 estantería 300 (16 Bandejas) / 60 Cajones 302 / 18 bolsas de 10 Separadores 02 1 Shelving 300 (16 Trays) / 60 Drawers 302 / 18 bags of 10 dividers 02 1 étagères 300 (16 Rayons) / 60 Tiroirs 302 / 18 sacs 10 séparateurs 02
399312	Kit estantería 402 Shelving kit 402 Set étagères 402	1030 x 437 x 2050 mm 40.55 x 17.20 x 80.71 in	1 estantería 400 (16 Bandejas) / 60 Cajones 402 / 30 bolsas de 10 Separadores 02 1 Shelving 400 (16 Trays) / 60 Drawers 402 / 30 bags of 10 dividers 02 1 étagères 400 (16 Rayons) / 60 Tiroirs 402 / 30 sacs 10 séparateurs 02



ESTANTERÍA SHELVING ÉTAGÈRE

Las bandejas de las estanterías tienen perforaciones, lo que te permite ajustar la altura de los estantes según tus necesidades. Las bandejas están hechas de acero con recubrimiento de pintura epoxi-poliéster, lo que las hace resistentes a la corrosión y duraderas.

The shelving trays have perforations, allowing you to adjust the height of the shelves according to your needs. The shelves are made of steel with epoxy-polyester paint coating, which makes them corrosion-resistant and durable.

Les plateaux d'étagères sont perforés, ce qui vous permet d'ajuster la hauteur des étagères en fonction de vos besoins. Les étagères sont fabriquées en acier et recouvertes d'une peinture époxy-polyester, ce qui les rend résistantes à la corrosion et durables.

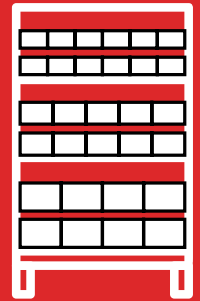

CÓDIGO CODE	MODELO MODEL / MODÈLE	L X A X H MEDIDAS SIZES / MESURES	CONTIENE CONTAINED / CONTIENT
398322	Kit estantería 303 Shelving kit 303 Set étagères 303	1030 x 337 x 2050 mm 40.55 x 13.27 x 80.71 in	1 Estantería 300 (12 Bandejas) / 48 Cajones 303 / 13 Bolsas de 10 / Separadores 03 1 Shelving 300 (12 Trays) / 48 Drawers 303 / 13 Bags of 10 dividers 03 1 Étagères 300 (12 Rayons) / 48 Tiroirs 303 / 13 Sacs 10 Séparateurs 03
399329	Kit estantería 403 Shelving kit 403 Set étagères 403	1030 x 437 x 2050 mm 40.55 x 17.20 x 80.71 in	1 estantería 400 (12 Bandejas) / 48 Cajones 403 / 15 bolsas de 10 / Separadores 03 1 Shelving 400 (12 Trays) / 48 Drawers 403 / 15 bags of 10 dividers 03 1 Étagères 400 (12 Rayons) / 48 Tiroirs 403 / 15 Sacs 10 Séparateurs 03



CÓDIGO CODE	MODELO MODEL / MODÈLE	L X A X H MEDIDAS SIZES / MESURES	CONTIENE CONTAINED / CONTIENT
398339	Kit estantería 310 Shelving kit 310 Set étagères 310	1030 x 337 x 2050 mm 40.55 x 13.27 x 80.71 in	1 estantería 300 (15 Bandejas) / 40 Cajones 301 / 20 Cajones 302 / 16 Cajones 303 / 6 bolsas de 20 Separadores 01 / 6 bolsas de 10 Separadores 02 / 4 bolsas de 10 Separadores 03 1 shelving 300 (15 Trays) / 40 Drawers 301 / 20 Drawers 302 / 16 Drawes 303 / 6 bags of 20 dividers 01 / 6 bags of 10 dividers 02 / 4 bags of 10 dividers 03 1 Étagères 300 (15 Rayons) / 40 Tiroirs 301 / 20 Tiroirs 302 / 16 Tiroirs 303 / 6 Sacs 20 Séparateurs 01 / 6 Sacs 10 Séparateurs 02 / 4 Sacs 10 Séparateurs 03
399336	Kit estantería 410 Shelving kit 410 Set étagères 410	1030 x 437 x 2050 mm 40.55 x 17.20 x 80.71 in	1 estantería 400 (15 Bandejas) / 40 Cajones 401 / 20 Cajones 402 / 16 Cajones 403 / 10 bolsas de 20 Separadores 01 / 10 bolsas de 10 Separadores 02 / 8 bolsas de 10 Separadores 03 1 shelving 400 (15 Trays) / 40 Drawers 401 / 20 Drawers 402 / 16 Drawes 403 / 10 bags of 20 dividers 01 / 10 bags of 10 dividers 02 / 8 bags of 10 dividers 03 1 Étagères 400 (15 Rayons) / 40 Tiroirs 401 / 20 Tiroirs 402 / 16 Tiroirs 403 / 10 Sacs 20 Séparateurs 01 / 10 Sacs 10 Séparateurs 02 / 8 Sacs 10 Séparateurs 03

ESTANTERÍA
SHELVING
ÉTAGÈRE

1.2.8. ESTANTERÍA METÁLICA METAL SHELVING ÉTAGÈRE EN MÉTAL



Puede montarse horizontal o verticalmente
Can be mounted horizontally or vertically
Peut être monté horizontalement ou verticalement



CÓDIGO
CODE

MODELO
MODEL / MODÈLE

L x A x H
MEDIDAS
SIZES / MESURES

CONTIENE
CONTAINED / CONTIENT

399602

Estantería
MDF
MDF Shelving
Étagères MDF

1800 x 900 x 400mm
70.87 x 35.43 x 15.75 in

4 Puntales, 10 Largueros VT, 10 Largueros VLTAM, 5
Tableros MDF, 8 Pies de plástico, 10 listones de soporte, 8
listones en L

4 Studs, 10 Transversal brackets VT, 10 Longitudinal
bracket VLTAM, 5 MDF Trays, 8 Plastic bottoms, 10 support
strips, 8 L-strips

4 Jambes de force, 10 BarresVT, 10 Barres VLTAM, 5
Étagères MDF, 8 pieds en plastique, 10 bandes de support
et 8 bandes en L



CAJONES ESTANTERÍAS
DRAWERS FOR SHELVES
TIROIRS ÉTAGÈRES



Etiquetas descargables en la web
Downloadable labels on the web
Étiquettes téléchargeables sur le site web



355004

356001

357008

360008

361005

362002

CÓDIGO CODE	MODELO MODEL MODÈLE	L x A x H MEDIDAS SIZES / MESURES	CAPACIDAD (LITROS) CAPACITY (LITRES) CAPACITÉ (LITRES)	MATERIAL MATERIAL MATÉRIAU	EMBALAJE / UNIDADES PACKING / UNITS EMBALLAGE / UNITÉS
355004	301	291 x 116 x 90 mm 11.46 x 4.57 x 3.54 in	2 L	Cajones PP Drawers PP Tiroirs PP	20
356001	302	291 x 232 x 90 mm 11.46 x 9.13 x 3.54 in	4,4 L	Cajones PP Drawers PP Tiroirs PP	10
357008	303	291 x 232 x 140 mm 11.46 x 9.13 x 5.51 in	7 L	Cajones PP Drawers PP Tiroirs PP	8
360008	401	391 x 116 x 90 mm 15.39 x 4.57 x 3.54 in	2,7 L	Cajones PP Drawers PP Tiroirs PP	20
361005	402	391 x 232 x 90 mm 15.39 x 9.13 x 3.54 in	6,1 L	Cajones PP Drawers PP Tiroirs PP	10
362002	403	391 x 232 x 140 mm 15.39 x 9.13 x 5.51 in	9,7 L	Cajones PP Drawers PP Tiroirs PP	8



390005



391002



392009

SEPARADORES
DIVIDERS
SÉPARATEURS

CÓDIGO CODE	MODELO MODEL MODÈLE	L x A x H MEDIDAS SIZES / MESURES	MATERIAL MATERIAL MATÉRIAU	UDS. BOLSA UNITS BAG UNITÉS SAC
390005	01	103 x 79 mm - 4.06 x 3.11 in	PP	20
391002	02	219 x 79 mm - 8.62 x 3.11 in	PP	10
392009	03	219 x 129 mm - 8.62 x 5.08 in	PP	10

1.2.9. ESTANTERÍAS. MÓDULO CAIRO SHELVES. CAIRO MODEL ÉTAGÈRE. MODÈLE CAIRO

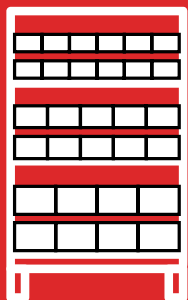

396045



396007

Con ruedas para un desplazamiento más sencillo
With wheels for easy transport
Avec des roues pour un déplacement facile

CÓDIGO
CODE

MODELO
MODEL / MODÈLE

L x A x H
MEDIDAS
SIZES / MESURES

CONTIENE
CONTAINED / CONTIENT

396045

Modelo simple con ruedas (7 alturas, 2 caras)

396298 ✂

Simple model with wheels (7 heights, 2 faces)

Modèle simple avec roues (7 hauteurs, 2 faces)

900 x 640 x 1305mm
35.43 x 25.20 x 51.38 in

6 líneas de 8 gavetas 51 = 48 gavetas= 2 cajas de 24
6 líneas de 5 gavetas 52 = 30 gavetas= 2 cajas de 15
2 líneas de 4 gavetas 55 = 8 gavetas = 1 caja de 8
6 lines 8 drawers 51 = 48 drawers = 2 boxes of 24
6 lines 5 drawers 52= 30 drawers = 2 boxes of 15
2 lines 4 drawers 55= 8 drawers = 1 box of 8
6 lignes 8 bac 51 = 48 bac = 2 boîtes en 24
6 lignes 5 bac 52= 30 bac = 2 boîtes en 15
2 lignes 4 bac 55= 8 bac = 1 boîte en 8

396007

Modelo doble con ruedas (10 alturas, 2 caras)

396250 ✂

Double model with wheels (10 heights, 2 faces)

Modèle double avec roues (10 hauteurs, 2 faces)

900 x 640 x 1800mm
35.43 x 25.20 x 70.87 in

9 líneas de 8 gavetas 51 = 72 gavetas= 3 cajas de 24
9 líneas de 5 gavetas 52 = 45 gavetas= 3 cajas de 15
2 líneas de 4 gavetas 55 = 8 gavetas = 1 caja de 8
9 lines 8 drawers 51 = 72 drawers = 3 boxes of 24
9 lines 5 drawers 52= 45 drawers = 3 boxes of 15
2 lines 4 drawers 55= 8 drawers = 1 box of 8
9 lignes 8 bac 51 = 72 bac = 3 boîtes en 24
9 lignes 5 bac 52= 45 bac = 3 boîtes en 15
2 lignes 4 bac 55= 8 bac = 1 boîte en 8

COLORES: AZUL / GRIS INDUSTRIAL
COLORS: BLUE / INDUSTRIAL GREY
COULEURS: BLEU / GRIS INDUSTRIEL

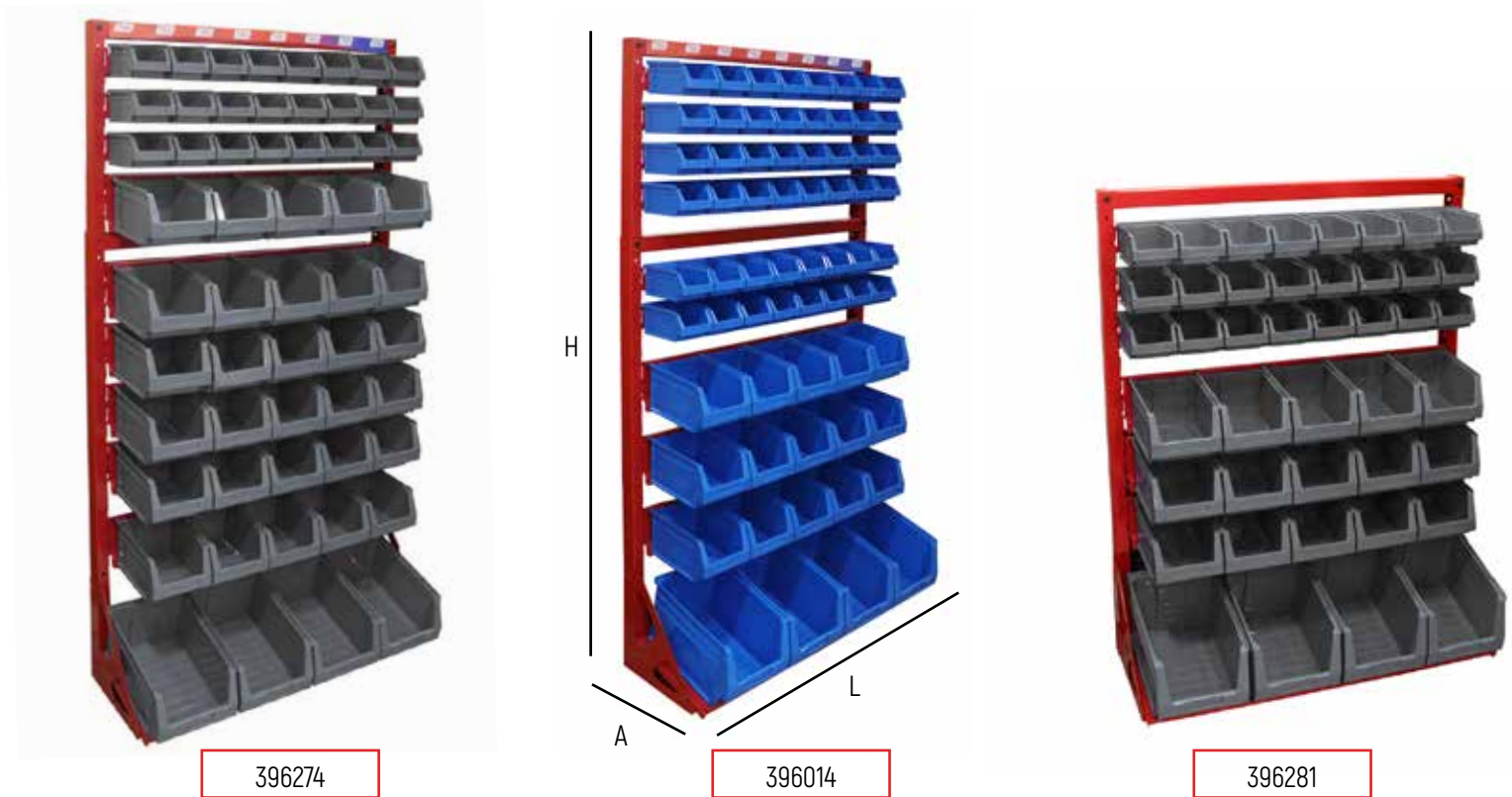

CÓDIGO
CODE

MODELO
MODEL / MODÈLE

L x A x H
MEDIDAS
SIZES / MESURES

CONTIENE
CONTAINED / CONTIENT

396021

Modelo serie B (10 alturas, 1 cara) sin ruedas
Serie B model (10 heights, 1 face) without wheels
Série Modèle B (10 hauteurs, 1 face) sans roues

396274 ~~X~~

900 x 400 x 1695mm
35.43 x 15.75 x 66.73 in

3 líneas de 8 gavetas 51 = 24 gavetas = 1 caja de 24
6 líneas de 5 gavetas 52 = 30 gavetas = 2 cajas de 15
1 línea de 4 gavetas 55 = 4 gavetas = 1 caja de 8 (sobran 4)

3 lines 8 drawers 51 = 24 drawers = 1 box of 24
6 lines 5 drawers 52 = 30 drawers = 2 boxes of 15
1 lines 4 drawers 55 = 4 drawers = 1 box of 8 (left 4)

3 lignes 8 bac 51 = 24 bac = 1 boîtes en 24
6 lignes 5 bac 52 = 30 bac = 2 boîtes en 15
1 lignes 4 bac 55 = 4 bac = 1 boîte en 8 (restants 4)

396014

Modelo serie A (10 alturas, 1 cara) sin ruedas
Serie A model (10 heights, 1 face) without wheels
Série Modèle A (10 hauteurs, 1 face) sans roues

396267 ~~X~~

900 x 400 x 1965mm
35.43 x 15.75 x 77.36 in

6 líneas de 8 gavetas 51 = 48 gavetas = 2 caja de 24
3 líneas de 5 gavetas 52 = 15 gavetas = 1 caja de 15
1 línea de 4 gavetas 55 = 4 gavetas = 1 caja de 8 (sobran 4)

6 lines 8 drawers 51 = 48 drawers = 2 box of 24
3 lines 5 drawers 52 = 15 drawers = 1 box of 15
1 lines 4 drawers 55 = 4 drawers = 1 box of 8 (left 4)

6 lignes 8 bac 51 = 48 bac = 2 boîtes en 24
3 lignes 5 bac 52 = 15 bac = 1 boîtes en 15
1 lignes 4 bac 55 = 4 bac = 1 boîte en 8 (restants 4)

396038

Modelo simple sin ruedas (7 alturas, 1 cara)
Simple model without wheels (7 heights, 1 face)
Modèle simple sans roues (7 hauteurs, 1 côté)

396281 ~~X~~

900 x 400 x 1200mm
35.43 x 15.75 x 47.24 in

3 líneas de 8 gavetas 51 = 24 gavetas = 1 caja de 24
3 líneas de 5 gavetas 52 = 15 gavetas = 1 caja de 15
1 línea de 4 gavetas 55 = 4 gavetas = 1 caja de 8 (sobran 4)

3 lines 8 drawers 51 = 24 drawers = 1 box of 24
3 lines 5 drawers 52 = 15 drawers = 1 box of 15
1 lines 4 drawers 55 = 4 drawers = 1 box of 8 (left 4)

3 lignes 8 bac 51 = 24 bac = 1 boîtes en 24
3 lignes 5 bac 52 = 15 bac = 1 boîtes en 15
1 lignes 4 bac 55 = 4 bac = 1 boîte en 8 (restants 4)

1.2.10. MÓDULOS METÁLICOS METAL STACKABLE MODULES MODULES MÉTALLIQUES

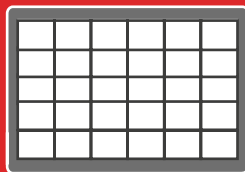

315602

317606

318603

316609

CÓDIGO CODE	MODELO MODEL MODÈLE	L x A x H MEDIDAS SIZES / MESURES	SEPARADOR CAJONES DRAWERS DIVIDERS SÉPARATEURS TIROIRS	MATERIAL MATERIAL / MATÉRIAU	EMBAJAJE / UNIDADES PACKING / UNITS EMBALLAGE / UNITÉS
315602	12/3/1	306 x 150 x 283 mm 12.05 x 5.91 x 11.14 in	12+3+1	Armazón-Chapa de acero, Cajones PP random Frame-Steel sheet, Drawers random PP Structure-Tôle en acier, Tiroirs PP random	4
317606	12/0/0	306 x 150 x 283 mm 12.05 x 5.91 x 11.14 in	12	Armazón-Chapa de acero, Cajones PP random Frame-Steel sheet, Drawers random PP Structure-Tôle en acier, Tiroirs PP random	4
318603	24/0/0	306 x 150 x 283 mm 12.05 x 5.91 x 11.14 in	24	Armazón-Chapa de acero, Cajones PP random Frame-Steel sheet, Drawers random PP Structure-Tôle en acier, Tiroirs PP random	4
316609	30/0/0	306 x 150 x 283 mm 12.05 x 5.91 x 11.14 in	30	Armazón-Chapa de acero, Cajones PP random Frame-Steel sheet, Drawers random PP Structure-Tôle en acier, Tiroirs PP random	4

1.2.11. CLASIFICADORES APILABLES STACKABLE CLASSIFIERS UNIT RACKS DE RANGEMENT APILABLES

ORDENACIÓN
ARRANGEMENT
RANGEMENT

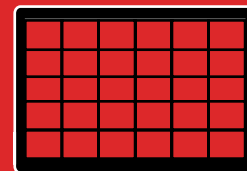

304002



306006



309007



312007

CÓDIGO CODE	L x A x H MEDIDAS SIZES / MESURES	GAVETAS DRAWERS / BACS	MEDIDAS GAVETAS DRAWER SIZES DIMENSIONS BACS	MATERIAL MATERIAL / MATÉRIAU	EMBAJAJE / UNIDADES PACKING / UNITS EMBALLAGE / UNITÉS
304002	360 x 170 x 190 mm 14.17 x 6.69 x 7.48 in	4	160 x 170 x 80 mm 6.30 x 6.69 x 3.15 in	Armazón PS / Gavetas PP Frame PS / Drawers PP Structure PS / Bacs PP	4
306006	360 x 170 x 190 mm 14.17 x 6.69 x 7.48 in	6	160 x 170 x 80 mm 6.30 x 6.69 x 3.15 in	Armazón PS / Gavetas PP Frame PS / Drawers PP Structure PS / Bacs PP	4
309007	360 x 170 x 190 mm 14.17 x 6.69 x 7.48 in	9	100 x 170 x 50 mm 3.94 x 6.69 x 1.97 in	Armazón PS / Gavetas PP Frame PS / Drawers PP Structure PS / Bacs PP	4
312007	360 x 170 x 190 mm 14.17 x 6.69 x 7.48 in	12	100 x 170 x 50 mm 3.94 x 6.69 x 1.97 in	Armazón PS / Gavetas PP Frame PS / Drawers PP Structure PS / Bacs PP	4

1.2.12. CONTENEDORES CAJONES Y MÓDULOS APILABLES CABINET STACKABLE DRAWERS AND MODULES CONTENEURS TIROIRS ET MODULES EMPILABLES

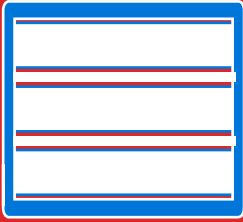

350009



351006



352003

CÓDIGO CODE	MODELO MODEL MODÈLE	L x A x H MEDIDAS SIZES / MESURES	MEDIDAS CAJONES DRAWERS SIZES TIROIRS MESURES	SEPARADOR CAJONES DRAWERS DIVIDERS SÉPARATEURS TIROIRS	MATERIAL MATERIAL / MATÉRIAU	EMBAJAJE / UNIDADES PACKING / UNITS EMBALLAGE / UNITÉS
350009	300/6	245 x 291 x 321 mm 9.65 x 11.46 x 12.64 in	6 291 x 116 x 95 mm 11.46 x 4.57 x 3.74 in	18 separadores dividers/séparateurs-01	Armazón PS / Cajones PP Frame PS / Drawers PP Structure PS / Tiroirs PP	2
351006	300/3	245 x 291 x 321 mm 9.65 x 11.46 x 12.64 in	3 291 x 232 x 95 mm 11.46 x 9.13 x 3.74 in	9 separadores dividers/séparateurs-02	Armazón PS / Cajones PP Frame PS / Drawers PP Structure PS / Tiroirs PP	2
352003	300/5	245 x 291 x 321 mm 9.65 x 11.46 x 12.64 in	4 - 291 x 116 x 95 mm 11.46 x 4.57 x 3.74 in 1 - 291 x 232 x 95 mm 11.46 x 9.13 x 3.74 in	12 separadores/dividers/ séparateurs-01 3 separadores/dividers/ séparateurs-02	Armazón PS / Cajones PP Frame PS / Drawers PP Structure PS / Tiroirs PP	2



ORDENACIÓN
ARRANGEMENT
RANGEMENT



346002



347009



348006

CÓDIGO CODE	L x A x H MEDIDAS SIZES / MESURES	MEDIDAS CAJONES DRAWERS SIZES TIROIRS MESURES	SEPARADOR CAJONES DRAWERS DIVIDERS SÉPARATEURS TIROIRS	MATERIAL MATERIAL / MATÉRIAU	EMBAJAJE / UNIDADES PACKING / UNITS EMBALLAGE / UNITÉS
346002	280 x 167 x 140 mm 11.02 x 6.57 x 5.51 in	6 127 x 150 x 37 mm 5.00 x 5.91 x 146 in	6	PS	6
347009	280 x 167 x 140 mm 11.02 x 6.57 x 5.51 in	3 - 127 x 150 x 37 mm 5.00 x 5.91 x 146 in 6 - 62 x 150 x 37 mm 2.44 x 5.91 x 146 in	3 6	PS	6
348006	280 x 167 x 140 mm 11.02 x 6.57 x 5.51 in	12 62 x 150 x 37 mm 2.44 x 5.91 x 146 in	12	PS	6



1.3

**HOGAR
HOME
FOYER**

**1.3.1. ESTUCHE HOGAR 76
HOME CASE
CAS D'ACCUEIL**

**1.3.2. HOME BOX 77
HOME BOX
HOME BOX**



1.3.1. ESTUCHE HOGAR HOME CASE CAS D'ACCUEIL



022593



023590

CÓDIGO CODE	L X A X H MEDIDAS SIZES / MESURES	MEDIDAS SIZES / MESURES	CONTIENE CONTAINED / CONTIENT	MATERIAL MATERIAL / MATÉRIAU	EMBAJAJE / UNIDADES PACKING / UNITS EMBALLAGE / UNITÉS
022593	22-26	312 x 238 x 51 mm 12.28 x 9.37 x 2.01 in	21 Separadores Dividers / Séparateurs	PP	6
023590	23-26	388 x 290 x 61 mm 15.28 x 11.42 x 2.40 in	21 Separadores Dividers / Séparateurs	PP	6

1.3.2. HOME BOX HOME BOX HOME BOX

HOGAR
HOME
FOYER



110597



111594



112591

CÓDIGO CODE	L x A x H MEDIDAS SIZES / MESURES	MEDIDAS SIZES / MESURES	CONTIENE CONTAINED / CONTIENT	MATERIAL MATERIAL / MATÉRIAU	EMBAJAJE / UNIDADES PACKING / UNITS EMBALLAGE / UNITÉS
110597	12"	290 x 170 x 127 mm 11.42 x 6.69 x 5.00 in	Bandeja / Tray / Panier porte-outils	PP	10
111594	14"	356 x 192 x 150 mm 14.02 x 7.56 x 5.91 in	Bandeja / Tray / Panier porte-outils	PP	6
112591	16"	400 x 217 x 166 mm 15.75 x 8.54 x 6.54 in	Bandeja / Tray / Panier porte-outils	PP	6



 **120L**
Contenedor residuos con pedal

1.4

EXTERIOR OUTSIDE EXTÉRIEUR

1.4.1. CONTENEDORES RESIDUOS 80
WASTE CONTAINER
BACS À DÉCHETS

1.4.2. BIDONES 88
JERRY CANS
JERRICAN

1.4.3. ESCOBAS TELESCÓPICAS 92
TELESCOPIC BROOMS
BALAIS TÉLESCOPIQUES





1.4.1. CONTENEDORES RESIDUOS WASTE CONTAINER BACS À DÉCHETS

CONTENEDORES RESIDUOS 50L
WASTE CONTAINER 50L
BACS À DÉCHETS 50L



434020



434037



430008



430015



412028



412035



412004



412011



412103

CÓDIGO
CODE

MODELO
MODEL / MODÈLE

L x A x H
MEDIDAS
SIZES / MESURES

CAPACIDAD
CAPACITY
CAPACITÉ

MATERIAL
MATERIAL
MATÉRIAU

EMBAJAJE / UNIDADES
PACKING / UNITS
EMBALLAGE / UNITÉS

434020

434037

434068

434013

50P

400 x 430 x 509 mm
15.75 x 16.93 x 20.04 in

50L

PP

3

430022

430039

430008

430015

50P

400 x 430 x 509 mm
15.75 x 16.93 x 20.04 in

50L

PP

3

412028

412035

412004

412011

412103

50

410 x 400 x 510 mm
16.14 x 15.75 x 20.08 in
Con cierres
With fastener
À attaches

50L

PP

4



ECO TAYG
ECO TAYG
ECO TAYG



435027

CONTENEDORES RESIDUOS 60L
WASTE CONTAINER 60L
BACS À DÉCHETS 60L



435034



431005



431012

CÓDIGO CODE	MODELO MODEL / MODÈLE	L x A x H MEDIDAS SIZES / MESURES	CAPACIDAD CAPACITY CAPACITÉ	MATERIAL MATERIAL MATÉRIAU	EMBAJAJE / UNIDADES PACKING / UNITS EMBALLAGE / UNITÉS
435027	60P	400 x 430 x 645 mm 15.75 x 16.93 x 25.39 in	60L	PP	3
435034					
435065					
435010	60P	400 x 430 x 645 mm 15.75 x 16.93 x 25.39 in	60L	PP	3
431029					
431036					
431005					
431012					



1.4.1. CONTENEDORES RESIDUOS WASTE CONTAINER BACS À DÉCHETS

CONTENEDORES RESIDUOS 75L
WASTE CONTAINER 75L
BACS À DÉCHETS 75L



411021



411038



411007



411014



411106

CÓDIGO CODE	MODELO MODEL / MODÈLE	L x A x H MEDIDAS SIZES / MESURES	CONTIENE CONTAINED CONTIENT	CAPACIDAD CAPACITY CAPACITÉ	MATERIAL MATERIAL MATÉRIAU	EMBAJAJE / UNIDADES PACKING / UNITS EMBALLAGE / UNITÉS
----------------	--------------------------	---	-----------------------------------	-----------------------------------	----------------------------------	--

411021
411038
411007
411014
411106

75

600 x 402 x 560 mm
23.62 x 15.83 x 22.05 in

Con cierres
With fastener
À attaches

75L

PP

4



ECO TAYG
ECO TAYG
ECO TAYG



CONTENEDORES RESIDUOS 80L
WASTE CONTAINER 80L
BACS À DÉCHETS 80L



432026



432033



433009



433016



433238

CÓDIGO CODE	MODELO MODEL / MODÈLE	L x A x H MEDIDAS SIZES / MESURES	CAPACIDAD CAPACITY CAPACITÉ	MATERIAL MATERIAL MATÉRIAU	EMBAJAJE / UNIDADES PACKING / UNITS EMBALLAGE / UNITÉS
432026 432033 432002 432019	80	400 x 575 x 785 mm 15.75 x 22.64 x 30.91 in	80L	PP	3
433023 433030 433009 433016 433238	80P	400 x 575 x 785 mm 15.75 x 22.64 x 30.91 in	80L	PP	3

ECO TAYG
ECO TAYG
ECO TAYG



1.4.1. CONTENEDORES RESIDUOS WASTE CONTAINER BACS À DÉCHETS

CONTENEDORES RESIDUOS 95L
WASTE CONTAINER 95L
BACS À DÉCHETS 95L



410024



410000



410017



410109

CÓDIGO
CODE

MODELO
MODEL / MODÈLE

L x A x H
MEDIDAS
SIZES / MESURES

CAPACIDAD
CAPACITY
CAPACITÉ

MATERIAL
MATERIAL
MATÉRIAU

EMBAJAJE / UNIDADES
PACKING / UNITS
EMBALLAGE / UNITÉS

410024
410031
410000
410017
410109

95

600 x 402 x 730 mm
23.62 x 15.83 x 28.74 in

95L

PP

4



ECO TAYG
ECO TAYG
ECO TAYG



CONTENEDORES RESIDUOS 100L
WASTE CONTAINER 100L
BACS À DÉCHETS 100L



CÓDIGO CODE	MODELO MODEL / MODÈLE	L x A x H MEDIDAS SIZES / MESURES	CAPACIDAD CAPACITY CAPACITÉ	MATERIAL MATERIAL MATERIAU	EMBAJAJE / UNIDADES PACKING / UNITS EMBALLAGE / UNITÉS
----------------	--------------------------	---	-----------------------------------	----------------------------------	--

420023

420030 *UV

420009

420016

420108

440076 *UV

420238

100

600 x 568 x 770 mm
23.62 x 22.36 x 30.31 in

100 L

PP

3

421020

421037 *UV

421006

421013

421105

441073 *UV

421235

100P

600 x 568 x 770 mm
23.62 x 22.36 x 30.31 in

100 L

PP

3

14.1. CONTENEDORES RESIDUOS WASTE CONTAINER BACS À DÉCHETS



CONTENEDORES RESIDUOS 120L
WASTE CONTAINER 120L
BACS À DÉCHETS 120L



422027



422034



423017



423109

CÓDIGO
CODE

MODELO
MODEL / MODÈLE

L x A x H
MEDIDAS
SIZES / MESURES

CAPACIDAD
CAPACITY
CAPACITÉ

MATERIAL
MATERIAL
MATÉRIAU

EMBAJAJE / UNIDADES
PACKING / UNITS
EMBALLAGE / UNITÉS

422027

422034 *UV

422003

422010

422102

442070 *UV

422232

423024

423031 *UV

423000

423017

423109

423239

120

120P

600 x 568 x 770 mm
23.62 x 22.36 x 30.31 in

600 x 568 x 770 mm
23.62 x 22.36 x 30.31 in

120 L

120 L

PP

PP

3

3



ECO TAYG
ECO TAYG
ECO TAYG

CONTENEDORES RESIDUOS 120L
WASTE CONTAINER 120L
BACS À DÉCHETS 120L



Con pedal central para fácil apertura
With pedal for easy opening
Avec pédale centrale pour une ouverture facile



443022



443015



443008



443237



424007



426001



443138

Protección contra rayos UVA
UV-A protection
Protection anti-rayons UVA

CÓDIGO CODE	MODELO MODEL / MODÈLE	L x A x H MEDIDAS SIZES / MESURES	CAPACIDAD CAPACITY CAPACITÉ	MATERIAL MATERIAL MATÉRIAU	EMBAJAJE / UNIDADES PACKING / UNITS EMBALLAGE / UNITÉS
443022					
443015	120 P	600 x 568 x 886 mm 23.62 x 22.36 x 34.88 in	120 L	PP	3
443008					
443237					
424007 *UV	120	600 x 568 x 886 mm 23.62 x 22.36 x 34.88 in	120 L	PP	3
426001 *UV	120P	600 x 568 x 886 mm 23.62 x 22.36 x 34.88 in	120 L	PP	3
443138 *UV					

1.4.2. BIDONES JERRY CANS JERRICAN



Toma de aire para un vertido uniforme
Air intake for uniform pouring
Prise d'air pour une décharge uniforme



Grifo para facilitar el vertido
Tap for easy pouring
Robinet pour faciliter le vidage



609008



610004



617003

CÓDIGO CODE	MODELO MODEL MODÈLE	CAPACIDAD CAPACITY CAPACITÉ
609008	Grifo / Tap / Robinet	5 L y 10 L
610004	Grifo / Tap / Robinet	20 L y 30 L
617003	Tapón / Plug / Bouchon	5 L, 10 L, 20L y 30 L



BIDONES
JERRY CANS
JERRICAN



Este bidón cumple con las normativas de seguridad y está homologado para el **contacto con alimentos**, lo que lo hace ideal para su uso en entornos domésticos o industriales. La durabilidad y resistencia del material garantizan un almacenamiento seguro a largo plazo.

This jerrycan complies with safety regulations and is approved for **contact with food**, making it ideal for use in domestic or industrial environments. The durability and resistance of the material ensure safe long-term storage.

Ce bidon est conforme aux normes de sécurité et homologué pour le **contact avec les aliments**, ce qui le rend idéal pour une utilisation dans des environnements domestiques ou industriels. La durabilité et la résistance du matériau garantissent un stockage sûr à long terme.

BIDONES CON GRIFO
JERRY CANS WITH TAP
JERRICAN AVEC ROBINET



601361



602368



603365



604362

CÓDIGO CODE	L x A x H MEDIDAS SIZES / MESURES	CAPACIDAD CAPACITY / CAPACITÉ	MATERIAL MATERIAL / MATÉRIAU	EMBAJAJE / UNIDADES PACKING / UNITS EMBALLAGE / UNITÉS
601361	230 x 145 x 257 mm 9.06 x 5.71 x 10.12 in	5 L	HDPE	6
602368	265 x 200 x 307 mm 10.43 x 7.87 x 12.09 in	10 L	HDPE	6
603365	345 x 234 x 377 mm 13.58 x 9.21 x 14.84 in	20 L	HDPE	5
604362	400 x 237 x 464 mm 15.75 x 9.33 x 18.27 in	30 L	HDPE	5

14.2. BIDONES JERRY CANS JERRICAN



607004



608001



616006



605000



606007



618000

CÓDIGO CODE	MODELO MODEL / MODÈLE	CAPACIDAD CAPACITY / CAPACITÉ
607004	Tapón / Plug / Bouchon	5 L y 10 L
608001	Tapón / Plug / Bouchon	20 L y 30 L
616006	Tapón respiradero / Vent plug / Bouchon de purge	5 L, 10 L, 20L y 30 L
605000	Cánula / Spout / Canule	5 L y 10 L
606007	Cánula / Spout / Canule	20 L y 30 L
618000	Embudo / Funnel / Entonnoir	

Válido para para todos los modelos de bidones
Suitable for all jerry cans models
Convient à tous les modèles de bidons



BIDONES
JERRY CANS
JERRICAN



Homologado para el transporte de materias peligrosas por carretera, ferrocarril, marítimo y aéreo, este bidón cumple con las normativas de seguridad más estrictas. Además, aguantan una **presión interna de 200kPa**.

Approved for the transport of hazardous materials by road, rail, sea, and air, this jerry can complies with the strictest safety regulations. In addition, they can withstand an **internal pressure of 200 kPa**.

Homologué pour le transport de matières dangereuses par route, rail, mer et air, ce bidon respecte les normes de sécurité les plus strictes. De plus, ils supportent une **pression interne de 200 kPa**.

BIDONES CON CÁNULA / COMBUSTIBLE
JERRY CANS WITH SPOUT / FUEL
BIDONS AVEC BEC / CARBURANT



601354



602351



603358



604355

CÓDIGO CODE	L x A x H MEDIDAS SIZES / MESURES	CAPACIDAD CAPACITY / CAPACITÉ	MATERIAL MATERIAL / MATÉRIAU	EMBAJAJE / UNIDADES PACKING / UNITS EMBALLAGE / UNITÉS
601354	230 x 145 x 257 mm 9.06 x 5.71 x 10.12 in	5 L	HDPE	6
602351	265 x 200 x 307 mm 10.43 x 7.87 x 12.09 in	10 L	HDPE	6
603358	345 x 234 x 377 mm 13.58 x 9.21 x 14.84 in	20 L	HDPE	5
604355	400 x 237 x 464 mm 15.75 x 9.33 x 18.27 in	30 L	HDPE	5

ESCOBAS
BROOMS
BALAIS

14.3. ESCOBAS TELESCÓPICAS TELESCOPIC BROOMS BALAIS TÉLESCOPIQUES

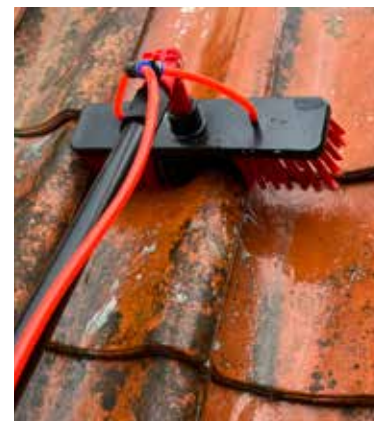
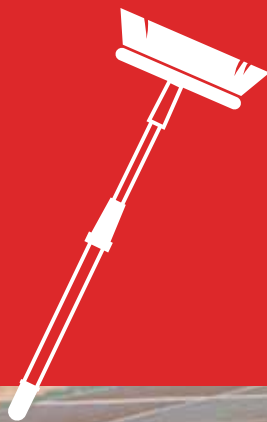

CÓDIGO CODE	MODELO MODEL / MODÈLE	L x A x H / MEDIDAS SIZES / MESURES	LONGITUD LENGTH / LONGUEUR	EMBAJAJE / UNIDADES PACKING / UNITS EMBALLAGE / UNITÉS
930034	4.6m	1185 x 125 x 110 mm 46,6 x 5 x 4,3 in	Min 1.3m - Max 4.6m Min 51,18in - Max 181,1in	8
930041	7m	1685 x 125 x 105 mm 66,34 x 5 x 4,1 in	Min 4.6m - Max 7m Min 181,1in - Max 275,6in	8

Modo de uso
Mode of use
Mode d'utilisation



ESCOBAS
BROOMS
BALAIS



Dispensador de jabón
Soap dispenser
Distributeur de savon



Agua continua (2 conectores)
Continuous water (2 connectors)
Eau continue (2 connecteurs)



Ángulo de rotación
Rotation angle
Angle de rotation



La Escoba Telescópica es una herramienta de limpieza versátil, ideal para alcanzar lugares altos como techos, ventanas y fachadas. Su mango telescópico ajustable y su fabricación en aluminio ligero aseguran durabilidad y fácil manejo. Cuenta con un cepillo innovador con manguera en forma de T para una distribución uniforme de agua y jabón, además de un dispensador integrado con botón dosificador. Es perfecta para uso doméstico y profesional.

The Telescopic Broom is a versatile cleaning tool, ideal for reaching high places such as ceilings, windows, and facades. Its adjustable telescopic handle and lightweight aluminum construction ensure durability and easy handling. It features an innovative brush with a T-shaped hose for even distribution of water and soap, as well as an integrated dispenser with a dosing button. It is perfect for both domestic and professional use.

Le Balai Téléscopique est un outil de nettoyage polyvalent, idéal pour atteindre des endroits élevés tels que les plafonds, fenêtres et façades. Son manche télescopique ajustable et sa fabrication en aluminium léger assurent durabilité et maniabilité facile. Il est équipé d'une brosse innovante avec un tuyau en forme de T pour une distribution uniforme de l'eau et du savon, ainsi qu'un distributeur intégré avec un bouton doseur. Il est parfait pour une utilisation domestique et professionnelle.



Cepillo de limpieza
Cleaning brush
Brosse de nettoyage



Adaptador de ángulo
Angle adapter
Adaptateur angulaire



Dispensador de jabón
Soap dispenser
Distributeur de savon



Manguera de agua
Water hose
Tuyau d'eau



Válvula de cierre
Stop valve
Vanne d'arrêt



2 TAYG LIGHT





2.1

ENROLLACABLES CABLE REELS ENROULEUR

2.1.1. ENROLLACABLES 98
CABLE REELS
ENROLEUR





2.1.1. ENROLLACABLES CABLE REELS ENROULEUR

ENROLLACABLES IP20 3.200W
CABLE REELS IP20 3.200W
ENROULEUR IP20 3.200W
CABLE: H05VV-F 3G1,5



IP 20
PROTECTION



CÓDIGO CODE	POTENCIA MÁXIMA MAX POWER PUISSANCE MAXIMALE	BASES SOCKETS ENTRÉES	CABLE CABLE	UNIDADES EMBALAJE PACKING UNITS UNITÉS D'EMBALLAGE
714603	230 V ~ 14A 3.200W	4 (2P+T) con termostato	H05VV-F 3G1,5 5m	10
729607	230 V ~ 14A 3.200W	4 (2P+T) with thermostat	H05VV-F 3G1,5 10m	10
734601	230 V ~ 14A 3.200W	4 (2P+T) avec thermostat	H05VV-F 3G1,5 15m	6



ENROLLACABLES
CABLE REELS
ENROULEUR

ENROLLACABLES IP20 4.000W
CABLE REELS IP20 4.000W
ENROULEUR IP20 4.000W
CABLE: H05VV-F 3G1,5



IP 20 **CE**
PROTECTION



Soporte metálico - Carrete de plástico
Metal bracket - Plastic spool
Support en métallique - Bobine en plastique

CÓDIGO CODE	POTENCIA MÁXIMA MAX POWER PUISSANCE MAXIMALE	BASES SOCKETS ENTRÉES	CABLE CABLE	DIÁMETRO DE CARRETE SPOOL DIAMETER DIAMÈTRE DE LA BOBINE	UNIDADES EMBALAJE PACKING UNITS UNITÉS D'EMBALLAGE
749605	250 V ~ 16A 4.000W	4 (2P+T) con termostato	H05VV-F 3G1,5 15m	210 mm	2
772603	250 V ~ 16A 4.000W	4 (2P+T) with thermostat 4 (2P+T) avec thermostat	H05VV-F 3G1,5 25m	240 mm	1
777608	250 V ~ 16A 4.000W		H05VV-F 3G1,5 50m	270 mm	1



2.1.1. ENROLLACABLES CABLE REELS ENROULEUR

ENROLLACABLES IP20 3.000W
CABLE REELS IP20 3.000W
ENROULEUR IP20 3.000W
CABLE: H05VV-F 3G1,5



IP 20
PROTECTION



IP-20
3.000 W

Soporte metálico - Base aérea - Carrete de plástico

Metal bracket - Air base - Plastic spool

Support en métallique - Base aérienne - Bobine en plastique



CÓDIGO
CODE

POTENCIA MÁXIMA
MAX POWER
PUISSANCE MAXIMALE

BASES
SOCKETS
ENTRÉES

CABLE
CABLE

DIÁMETRO DE CARRETE
SPOOL DIAMETER
DIAMÈTRE DE LA BOBINE

UNIDADES EMBALAJE
PACKING UNITS
UNITÉS D'EMBALLAGE

774607

230 V ~ 13A 3.000W

Base aérea
Air base
Base aérienne

H05VV-F 3G1,5 25m

240 mm

1

ENROLLACABLES
CABLE REELS
ENROULEUR



Soporte metálico - Carrete de plástico
Metal bracket - Plastic spool
Support en métallique - Bobine en plastique

ENROLLACABLES IP44 3.000W
CABLE REELS IP44 3.000W
ENROULEUR IP44 3.000W
CABLE: H05VV-F 3G1,5

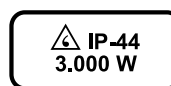

CÓDIGO CODE	POTENCIA MÁXIMA MAX POWER PUISSANCE MAXIMALE	BASES SOCKETS ENTRÉES	CABLE CABLE	DIÁMETRO DE CARRETE SPOOL DIAMETER DIAMÈTRE DE LA BOBINE	UNIDADES EMBALAJE PACKING UNITS UNITÉS D'EMBALLAGE
761607	230 V ~ 13A 3.000W	4 (2p+t) con termostato con tapa 4 (2p+t) with thermostat and cover	H05VV-F 3G1,5 25m	270 mm	1
764608	230 V ~ 13A 3.000W	4 (2p+t) avec thermostat et couvercle	H05VV-F 3G1,5 50m	270 mm	1

ENROLLACABLES
CABLE REELS
ENROULEUR



2.1.1. ENROLLACABLES CABLE REELS ENROULEUR



Soporte y carrete metálico
Metal spool and metal frame
Support et bobine en métallique

ENROLLACABLES IP44 7.000W
CABLE REELS IP44 7.000W
ENROULEUR IP44 7.000W
CABLE: H05VV-F 4G1,5



WATERPROOF
IP 44
PROTECTION

CE

IP-44
7.300 W

CÓDIGO CODE	POTENCIA MÁXIMA MAX POWER PUISSANCE MAXIMALE	BASES SOCKETS ENTRÉES	CABLE CABLE	DIÁMETRO DE CARRETE SPOOL DIAMETER DIAMÈTRE DE LA BOBINE	UNIDADES EMBALAJE PACKING UNITS UNITÉS D'EMBALLAGE
760518	400 V ~ 16A 7.300W	2 (3P+T6h 380V) con termostato y tapa with thermostat and cover	H05VV-F 4G1,5 25m	280 mm	1
780516	400 V ~ 16A 7.300W	2 (3P+T6h 380V) avec thermostat et couvercle	H05VV-F 4G1,5 40m	280 mm	1



ENROLLACABLES
CABLE REELS
ENROULEUR



ENROLLACABLES IP55 3.500W
CABLE REELS IP55 3.500W
ENROULEUR IP55 3.500W
CABLE: H05VV-F 3G1,5

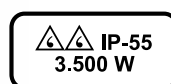
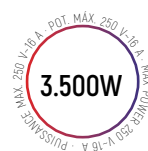

CÓDIGO CODE	POTENCIA MÁXIMA MAX POWER PUISSANCE MAXIMALE	BASES SOCKETS ENTRÉES	CABLE CABLE	DIÁMETRO DE CARRETE SPOOL DIAMETER DIAMÈTRE DE LA BOBINE	UNIDADES EMBALAJE PACKING UNITS UNITÉS D'EMBALLAGE
765001	250 V ~ 3500 W	3 (2P+T) con termostato y tapa 3 (2P+T) with thermostat and cover	H05VV-F 3G1,5 25m	290 mm	1
766008	250 V ~ 3500 W	3 (2P+T) avec thermostat et couvercle	H05VV-F 3G1,5 50m	290 mm	1



ENROLLACABLES IP55 4.000W
CABLE REELS IP55 4.000W
ENROULEUR IP55 4.000W
CABLE: H05VV-F 3G2,5

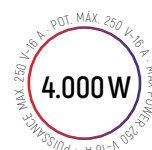

CÓDIGO CODE	POTENCIA MÁXIMA MAX POWER PUISSANCE MAXIMALE	BASES SOCKETS ENTRÉES	CABLE CABLE	DIÁMETRO DE CARRETE SPOOL DIAMETER DIAMÈTRE DE LA BOBINE	UNIDADES EMBALAJE PACKING UNITS UNITÉS D'EMBALLAGE
785009	250 V ~ 4000 W	3 (2P+T) con termostato y tapa 3 (2P+T) with thermostat and cover	H05VV-F 3G2,5 25m	290 mm	1
786006	250 V ~ 4000 W	3 (2P+T) avec thermostat et couvercle	H05VV-F 3G2,5 50m	290 mm	1



2.1.1. ENROLLACABLES CABLE REELS ENROULEUR



ENROLLACABLES IP55 3.000W
CABLE REELS IP55 3.000W
ENROULEUR IP55 3.000W
CABLE: H05RR-F 3G1,5



CÓDIGO CODE	POTENCIA MÁXIMA MAX POWER PUISSANCE MAXIMALE	BASES SOCKETS ENTRÉES	CABLE CABLE	DIÁMETRO DE CARRETE SPOOL DIAMETER DIAMÈTRE DE LA BOBINE	UNIDADES EMBALAJE PACKING UNITS UNITÉS D'EMBALLAGE
789601	230 V ~ 3000 W	3 (2P+T) con termostato y tapa 3 (2P+T) with thermostat and cover	H05RR-F 3G1,5 25m	240 mm	1
790607	230 V ~ 3000 W	3 (2P+T) avec thermostat et couvercle	H05RR-F 3G1,5 50m	300 mm	1

ENROLLACABLES IP55 3.000W
CABLE REELS IP55 3.000W
ENROULEUR IP55 3.000W
CABLE: H07RN-F 3G1,5

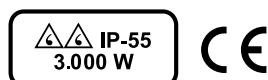
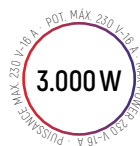

CÓDIGO CODE	POTENCIA MÁXIMA MAX POWER PUISSANCE MAXIMALE	BASES SOCKETS ENTRÉES	CABLE CABLE	DIÁMETRO DE CARRETE SPOOL DIAMETER DIAMÈTRE DE LA BOBINE	UNIDADES EMBALAJE PACKING UNITS UNITÉS D'EMBALLAGE
791604	230 V ~ 3000 W	3 (2P+T) con termostato y tapa 3 (2P+T) with thermostat and cover 3 (2P+T) avec thermostat et couvercle	H07RN-F 3G1,5 25m	270 mm	1

ENROLLACABLES IP55 3.600W
CABLE REELS IP55 3.600W
ENROULEUR IP55 3.600W
CABLE: H07RN-F 3G2,5

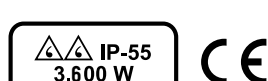
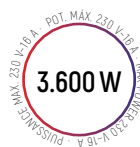

CÓDIGO CODE	POTENCIA MÁXIMA MAX POWER PUISSANCE MAXIMALE	BASES SOCKETS ENTRÉES	CABLE CABLE	DIÁMETRO DE CARRETE SPOOL DIAMETER DIAMÈTRE DE LA BOBINE	UNIDADES EMBALAJE PACKING UNITS UNITÉS D'EMBALLAGE
792601	230 V ~ 3600 W	3 (2P+T) con termostato y tapa 3 (2P+T) with thermostat and cover 3 (2P+T) avec thermostat et couvercle	H07RN-F 3G2,5 25m	270 mm	1



ENROLLACABLES
CABLE REELS
ENROULEUR

ENROLLACABLES IP55 4.000W
CABLE REELS IP55 4.000W
ENROULEUR IP55 4.000W
CABLE: H05VV-F 3G2,5

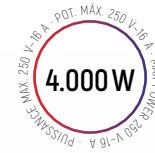

Enrollacable con apliche francés
Cable reel with french connection
Enroleur avec prise français

CÓDIGO CODE	POTENCIA MÁXIMA MAX POWER PUISSANCE MAXIMALE	BASES SOCKETS ENTRÉES	CABLE CABLE	DIÁMETRO DE CARRETE SPOOL DIAMETER DIAMÈTRE DE LA BOBINE	UNIDADES EMBALAJE PACKING UNITS UNITÉS D'EMBALLAGE
785511	250 V ~ 4.000W	3 (2P+T) con termostato y tapa 3 (2P+T) with thermostat and cover	H05VV-F 3G2,5 25m	280 mm	1
786518	250 V ~ 4.000W	3 (2P+T) avec thermostat et couvercle	H05VV-F 3G2,5 50m	280 mm	1
785528	250 V ~ 4.000W	3 (2P+T6h) con termostato y tapa 3 (2P+T6h) with thermostat and cover	H05VV-F 3G2,5 25m	280 mm	1
786525	250 V ~ 4.000W	3 (2P+T6h) avec thermostat et couvercle	H05VV-F 3G2,5 50m	280 mm	1

* Cod. 785511 y 786518. Países homologados para uso.

El apliche español: Spanish connection: / Prise español: Holanda, Luxemburgo, Austria, Croacia, Suiza, Portugal, Lituania, Grecia, Chipre, Albania, Andorra, Rusia, Bielorusia, Bosnia, Bulgaria, Republica Checa, Estonia, Islas Feroe, Finlandia, Alemania, Hungría, Islandia, Lituania, Letonia, Macedonia, Mónaco, Noruega, Rumania, Eslovenia, Ucrania, Serbia, Montenegro.

El apliche francés: French connection: / Prise français: Bélgica, Eslovaquia y Túnez.

ENROLLACABLES
CABLE REELS
ENROULEUR

2.11. ENROLLACABLES CABLE REELS ENROULEUR



ENROLLACABLES IP55 3.500W
CABLE REELS IP55 3.500W
ENROULEUR IP55 3.500W
CABLE: **H07RN-F 3G1,5**



Cable: Goma/Neopreno
Cable: Rubber/Neoprene
Cable: Caoutchouc/néoprène



*Para instaladores eléctricos: cumple con la instrucción técnica complementaria nº33 del reglamento de baja tensión.

*For electrical installers: Comply with Complementary Technical Instruction nº 33 of the Spanish Low Voltage Electrical. Installation Regulations.

*Pour les installateurs électriques: Conforme avec la norme technique nº33 du règlement de basse tension espagnol

CÓDIGO CODE	POTENCIA MÁXIMA MAX POWER PUISSANCE MAXIMALE	BASES SOCKETS ENTRÉES	CABLE CABLE	DIÁMETRO DE CARRETE SPOOL DIAMETER DIAMÈTRE DE LA BOBINE	UNIDADES EMBALAJE PACKING UNITS UNITÉS D'EMBALLAGE
765506	250 V ~ 3.500W	3 (2P+T) con termostato y tapa 3 (2P+T) with thermostat and cover	H07RN-F 3G1,5 25 m	280 mm	1
766503	250 V ~ 3.500W	3 (2P+T) avec thermostat et couvercle	H07RN-F 3G1,5 50 m	280 mm	1
CÓDIGO CODE	POTENCIA MÁXIMA MAX POWER PUISSANCE MAXIMALE	BASES SOCKETS ENTRÉES	CABLE CABLE	DIÁMETRO DE CARRETE SPOOL DIAMETER DIAMÈTRE DE LA BOBINE	UNIDADES EMBALAJE PACKING UNITS UNITÉS D'EMBALLAGE
795503	250 V ~ 4.000W	3 (2P+T) con termostato y tapa 3 (2P+T) with thermostat and cover 3 (2P+T) avec thermostat et couvercle	H07RN-F 3G2,5 25 m	280 mm	1



ENROLLACABLES
CABLE REELS
ENROULEUR

ENROLLACABLES IP67 3.500W
CABLE REELS IP67 3.500W
ENROULEUR IP67 3.500W
CABLE: H07RN-F 3G1,5

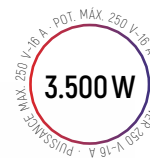

*Para instaladores eléctricos: cumple con la instrucción técnica complementaria nº33 del reglamento de baja tensión.

*For electrical instalers: Comply with Complementary Technical Instruction nº 33 of the Spanish Low Voltage Electrical. Installation Regulations.

*Pour les installateurs électriques: Conforme avec la norme technique nº33 du règlement de basse tension espagnol

Soporte y carrete metálico
Metal spool and metal frame
Support et bobine en métallique

CÓDIGO CODE	POTENCIA MÁXIMA MAX POWER PUISSANCE MAXIMALE	BASES SOCKETS ENTRÉES	CABLE CABLE	DIÁMETRO DE CARRETE SPOOL DIAMETER DIAMÈTRE DE LA BOBINE	UNIDADES EMBALAJE PACKING UNITS UNITÉS D'EMBALLAGE
767500	250 V ~ 3.500W	2 (2P+T) con termostato y tapa 2 (2P+T) with thermostat and cover 2 (2P+T) avec thermostat et couvercle	H07RN-F 3G1,5 25 m Goma/Neopreno Rubber/Neoprene Caoutchouc/néoprène	280 mm	1
768507	250 V ~ 3.500W		H07RN-F 3G1,5 50 m Goma/Neopreno Rubber/Neoprene Caoutchouc/néoprène	280 mm	1



2.2

PROYECTOR LED LED WORKLIGHT PROJECTEUR LED

2.2.1. PROYECTORES LED IP65 110
LED WORKLIGHT
PROJECTEUR LED IP65

2.2.2. PROYECTOR LED CON SOPORTE 111
LED WORKLIGHT WITH STAND
PROJECTEUR LED AVEC SUPPORT

2.2.3. PROYECTOR LED CON TRÍPODE 112
LED WORKLIGHT WITH TRIPOD
PROJECTEUR LED AVEC TRÉPIED





2.2.1. PROYECTORES LED IP65 LED WORKLIGHT IP65 PROJECTEUR LED IP65

LED



WATERPROOF
IP65
PROTECTION



510601



512605



513602



524608

CÓDIGO CODE	MODELO MODEL / MODÈLE	L x A x H MEDIDAS SIZES / MESURES	POTENCIA MÁXIMA MAX POWER PUISSANCE MAXIMALE	VOLTAJE VOLTAGE TENSION	UNIDADES EMBALAJE PACKING UNITS UNITÉS D'EMBALLAGE
510601	10W IP65 800lm	125 x 50 x 116 mm 4.92 x 1.97 x 4.57 in	10W - 800Lm	220-240V ~ 50-60Hz	24
512605	30W IP65 2400lm	145 x 27 x 130 mm 5.71 x 1.06 x 5.12 in	30W - 2400Lm	220-240V ~ 50-60Hz	6
513602	50W IP65 4000lm	180 x 28 x 165 mm 7.09 x 1.10 x 6.50 in	50W - 4000Lm	220-240V ~ 50-60Hz	6
524608	100W IP65 8000lm	239 x 34 x 214 mm 9.41 x 1.34 x 8.43 in	100W - 8000Lm Cable 0.15m H05RN-F 3G1.0mm ²	220-240V ~ 50Hz	10

2.2.2. PROYECTOR LED CON SOPORTE LED WORKLIGHT WITH STAND PROJECTEUR LED AVEC SUPPORT

PROYECTORES
WORKLIGHT
PROJECTEUR



LED



WATERPROOF
IP65
PROTECTION



CÓDIGO CODE	MODELO MODEL / MODÈLE	L x A x H MEDIDAS SIZES / MESURES	POTENCIA MÁXIMA MAX POWER PUISSANCE MAXIMALE	VOLTAJE VOLTAGE TENSION	UNIDADES EMBALAJE PACKING UNITS UNITÉS D'EMBALLAGE
515606	Proyector led 30W IP65 con soporte 2400lm Led worklight 30W IP65 with stand 2400lm Projecteur led 30W IP65 avec support 2400lm	228x 123 x 183 mm 8.98 × 4.84 × 7.20 in	30W - 2400Lm	220-240V ~ 50-60Hz H05RN-F 3G 1,0mm ² 1,5m	8
516603	Proyector led 50W IP65 con soporte 4000lm Led worklight 50W IP65 with stand 4000lm Projecteur led 50W IP65 avec support 4000lm	228 x 123 x 262 mm 8.98 × 4.84 × 10.31 in	50W - 4000Lm	220-240V ~ 50-60Hz H05RN-F 3G 1,0mm ² 1,5m	4

PROYECTORES
WORKLIGHT
PROJECTEUR



2.2.3. PROYECTOR LED CON TRÍPODE LED WORKLIGHT WITH TRIPOD PROJECTEUR LED AVEC TRÉPIED



CÓDIGO CODE	MODELO MODEL / MODÈLE	L x A x H MEDIDAS SIZES / MESURES	POTENCIA MÁXIMA MAX POWER PUISSANCE MAXIMALE	VOLTAJE VOLTAGE TENSION	VOLTAJE VOLTAGE TENSION	UNDS. EMBALAJE PACKING UNITS UNITÉS D'EMBALLAGE
517600	Proyector led 50W IP65 con trípode 4000lm Led worklight 50W IP65 with tripod 4000lm Projecteur led 50W IP65 avec trépied 4000lm	780 x 780 x 1675 mm	50W - 4000Lm	220-240V 50-60Hz	H05RN-F 3G 1,0mm ² 2,5m	4
518607	Proyector led 2x50W IP65 con trípode 8000lm Led worklight 2x50W IP65 with tripod 8000lm Projecteur led 2x50W IP65 avec trépied 8000lm	780 x 780 x 1695 mm	2 x 50W 8000Lm	220-240V ~ 50-60Hz	H05RN-F 3G 1,0mm ² 3m	4

LED

WATERPROOF
IP65
PROTECTION

LUZ BLANCA · WHITE LIGHT
6500°K
LUMIERE BLANCHE ·



PROYECTORES
WORKLIGHT
PROJECTEUR



518607



517600



2.3

LÁMPARAS LED PENLIGHT LED LAMPES À LED

2.3.1. LINTERNA FRONTAL MULTIFUNCIONAL 116
MULTIFUNCTIONAL HEAD LAMP
LAMPE FRONTALE MULTIFONCTIONNELLE

2.3.2. LÁMPARA PORTÁTIL 116
PORTABLE LIGHT
LAMPE PORTABLE

2.3.3. LED TRABAJO MULTIFUNCIÓN X5 117
MULTIFUNCTION LED WORKLIGHT X5
LAMPE DE TRAVAIL LED MULTIFUNCTION X5

2.3.4. LED 3 EN 1 117
LED 3 IN 1
LED 3 DANS 1





2.3.1. LINTERNA FRONTAL MULTIFUNCIONAL MULTIFUNCTIONAL HEAD LAMP LAMPE FRONTALE MULTIFONCTIONNELLE



Resistencia al impacto 1M
Impact resistant 1M
Résistance aux chocs 1M



Carga USB
USB charge
Recharge USB



Autonomía 4h HIGH - 12h LOW
Runtime 4h HIGH - 12h LOW
Autonomie 4h HIGH - 12h LOW



Luminosidad 150LM
Brightness 150LM
Luminosité 150LM

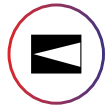

Alcance 20M
Effective range 20M
Portée de la lumière 20M



Resistente al agua IPX4
Water resistant IPX4
Résistant à l'eau IPX4

CÓDIGO CODE	POTENCIA MÁXIMA MAX POWER PUISSANCE MAXIMALE	UNDS. EMBALAJE PACKING UNITS UNITÉS D'EMBALLAGE
504600	150 LM	6

2.3.2. LÁMPARA PORTÁTIL 3 EN 1 PORTABLE LIGHT 3 IN 1 LAMPE PORTABLE 3 DANS 1

Lámpara 3W COB 200lm
3W COB lamp 200lm
Lampe 3W COB 200lm

Luz de advertencia: LEDs rojos
Warning light: red LEDs
Lumière d'avertissement: LED rouges

Linterna 1W LED 60lm
1W LED flashlight 60lm
Lanterne 1W LED 60lm

CÓDIGO CODE	POTENCIA MÁXIMA MAX POWER PUISSANCE MAXIMALE	UNDS. EMBALAJE PACKING UNITS UNITÉS D'EMBALLAGE
508608	200 + 60 LM	6



2.3.3. LED TRABAJO MULTIFUNCIÓN X5 MULTIFUNCTION LED WORKLIGHT X5 LAMPE DE TRAVAIL LED MULTIFUNCTION X5

LÁMPARAS
PENLIGHT
LAMPES



Base retráctil / pinza
Retractable base / clamp
Base rétractable / pince



Imán y gancho en la parte inferior
Hook and magnet on the bottom
Crochet et aimant de fond



Luz frontal
Head light
Lampe frontale



Imán en la parte superior
Magnet on the top
Aimant sur le dessus



Carga USB - Indicador de batería
USB charge - Power indicator
Recharge USB - Indicateur de batterie



180° Rotación
180° Rotate
180° Rotation



CÓDIGO CODE	POTENCIA MÁXIMA MAX POWER PUISSANCE MAXIMALE	UNDS. EMBALAJE PACKING UNITS UNITÉS D'EMBALLAGE
505607	180 LM	6

2.3.4. LED 3 EN 1 LED 3 IN 1 LED 3 DANS 1

Cabeza linterna
Flashlight head
Tête de lampe de poche

Cuello de cisne flexible
Flexible gooseneck head
Col de cygne flexible



Cabezal trabajo led
Worklight head
Tête de lampe de travail



Puerto micro USB
Micro USB port
Port micro USB



CÓDIGO
CODE

POTENCIA MÁXIMA
MAX POWER
PUISSANCE MAXIMALE

UNDS. EMBALAJE
PACKING UNITS
UNITÉS D'EMBALLAGE

507601

380 LM

6





2.4

**BASES MÚLTILES Y
PROLONGADORES
ELÉCTRICOS**

**MULTIPLE SOCKETS AND
EXTENSION CABLES**

**PRISAS MULTIPLES ET
RALLONGES**

**2.4.1. BASES MÚLTIPLES 120
MULTIPLE SOCKETS
PRISES MULTIPLES**

**2.4.2. PROLONGADORES ELÉCTRICOS 122
EXTENSION CABLES
RALLONGES ÉLECTRIQUES**



2.4.1. BASES MÚLTIPLES MULTIPLE SOCKETS PRISES MULTIPLES

BASES MÚLTIPLES CON INTERRUPTOR
MULTIPLE SOCKETS WITH SWITCH
PRISES MULTIPLES AVEC INTERUPTEUR

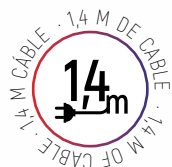
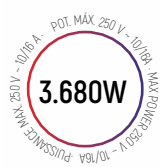
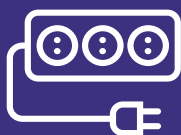

811609



801600



806605



808609

CÓDIGO CODE	MODELO MODEL MODÈLE	POTENCIA MÁXIMA MAX POWER PUISSANCE MAXIMALE	CABLE CABLE	UNIDADES EMBALAJE PACKING UNITS UNITÉS D'EMBALLAGE
801600	3 BASES 2P + T con interruptor 3 sockets 2P + T with switch 3 entrées 2P + T avec interrupteur	250 V ~ 10/16A 3.680W	H05VV-F 3G1,5 1,4m	10
806605	4 BASES 2P + T con interruptor 4 sockets 2P + T with switch 4 entrées 2P + T avec interrupteur	250 V ~ 10/16A 3.680W	H05VV-F 3G1,5 1,4m	10
808609	5 BASES 2P + T con interruptor 5 sockets 2P + T with switch 5 entrées 2P + T avec interrupteur	250 V ~ 10/16A 3.680W	H05VV-F 3G1,5 1,4m	10
811609	6 BASES 2P + T con interruptor 6 sockets 2P + T with switch 6 entrées 2P + T avec interrupteur	250 V ~ 10/16A 3.680W	H05VV-F 3G1,5 1,4m	10

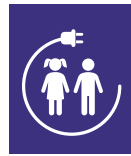

BASES
SOCKETS
PRISES

BASES MÚLTIPLES CON INTERRUPTOR Y PROTECTOR SOBRETENSIÓN
MULTIPLE SOCKETS WITH SWITCH AND VOLTAGE PROTECTION
PRISES MULTIPLES AVEC INTERUPTEUR ET PARASURTENSEUR

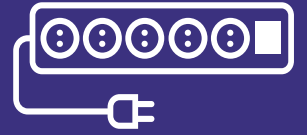
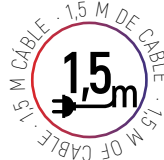
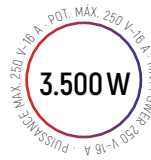

CÓDIGO CODE	MODELO MODEL MODÈLE	POTENCIA MÁXIMA MAX POWER PUISSANCE MAXIMALE	CABLE CABLE	UNIDADES EMBALAJE PACKING UNITS UNITÉS D'EMBALLAGE
814600	4 bases 2p + t con interruptor y protección sobre-tensión 4 sockets 2p + t with switch and voltage protection 4 entrées 2p + t avec interupteur et parasurtenseur	250 V ~ 16A 3.500W	H05VV-F 3G1,5 1,5m	6
816604	6 bases 2p + t con interruptor y protección sobre-tensión 6 sockets 2p + t with switch and voltage protection 6 entrées 2p + t avec interupteur et parasurtenseur	250 V ~ 16A 3.500W	H05VV-F 3G1,5 1,5m	6
818608	8 bases 2p + t con interruptor y protección sobre-tensión 8 sockets 2P + T with switch and voltage protection 8 entrées 2P + T avec interupteur et parasurtenseur	250 V ~ 16A 3.500W	H05VV-F 3G1,5 1,5m	6

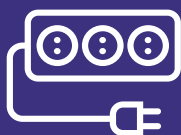

2.4.2. PROLONGADORES ELÉCTRICOS EXTENSION CABLES RALLONGES ÉLECTRIQUES

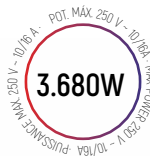
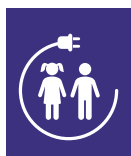

CÓDIGO CODE	POTENCIA MÁXIMA MAX POWER PUISSANCE MAXIMALE	CLAVIJA Y BASE PLUG AND SOCKET PRISE + PRISE ÉLECTRIQUE	CABLE CABLE	UNIDADES EMBALAJE PACKING UNITS UNITÉS D'EMBALLAGE
570001	250V-16A 3.680W	2P+T	H05VV-F 3G1,5 2m	10
571008	250V-16A 3.680W	2P+T	H05VV-F 3G1,5 3m	10
572005	250V-16A 3.680W	2P+T	H05VV-F 3G1,5 4m	10



PROLONGADORES
EXTENSION
RALLONGES

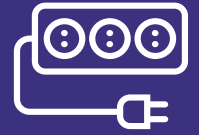

CÓDIGO CODE	POTENCIA MÁXIMA MAX POWER PUISSANCE MAXIMALE	CLAVIJA Y BASE PLUG AND SOCKET PRISE + PRISE ÉLECTRIQUE	CABLE CABLE	UNIDADES EMBALAJE PACKING UNITS UNITÉS D'EMBALLAGE
575006	250V-16A 3.680W	2P+T	H05VV-F 3G1,5 10m	6
576003	250V-16A 3.680W	2P+T	H05VV-F 3G1,5 15m	6
577000	250V-16A 3.680W	2P+T	H05VV-F 3G1,5 25m	6



WATERPROOF
IP 44
PROTECTION

PROLONGADOR CAMPING
CAMPING EXTENSION
EXTENSION DU CAMPING

CÓDIGO CODE	POTENCIA MÁXIMA MAX POWE PUISSANCE MAXIMALE	CLAVIJA Y BASE PLUG AND SOCKET PRISE + PRISE ÉLECTRIQUE	CABLE CABLE	UNIDADES EMBALAJE PACKING UNITS UNITÉS D'EMBALLAGE
578007	230V-16A 3.680W	2P+T6h	H07RN-F 3G1,5 10m	6



3 TAYG BUILD





3.1

DISTANCIADORES DE PAVIMENTO Y SISTEMAS DE NIVELACIÓN

PAVEMENT SPACERS AND LEVELLING SYSTEMS

ENTRETOISES ET SYSTÈMES DE NIVELLEMENT

3.1.1. SISTEMA DE NIVELACIÓN 128
LEVELLING SYSTEM
SYSTÈME DE NIVELLEMENT

3.1.2. CRUCETAS 130
TILE SPACER
CROISILLONS

3.1.3. KIT SISTEMA DE NIVELACIÓN 131
LEVELLING SYSTEM KIT
KIT SYSTÈME DE NIVELLEMENT

3.1.4. TAYG PRO 131
TAYG PRO
TAYG PRO

3.1.5. ACCESORIOS DE NIVELACIÓN 133
LEVELLING SYSTEM ACCESSORIES
ACCESSOIRES DE MISE À NIVEAU

3.1.6. TAYG ROLL 135
TAYG ROLL
TAYG ROLL



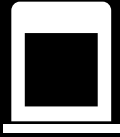

3.1.1. SISTEMA DE NIVELACIÓN LEVELLING SYSTEM SYSTÈME DE NIVELLEMENT

H: 3-12 MM
BASE NIVELACIÓN
LEVELLING BASE
BASE DE NIVELLEMENT



Calculadora de bases
Bases calculator
Calculateur de bases



CÓDIGO CODE	MEDIDAS SIZES / MESURES	UDS. BOLSA UNITS BAG / UNITÉS SACHET	UDS. CAJA UNITS PACK / UNITÉS PACK	CAJAS PALET PACKS PALLET
912603	Base 0,5 mm - 1/64"	250 Poliamida	14 bolsas / 3.500 uds. caja	16
913006		100	35 bolsas / 3.500 uds. caja	16
913013	Base 1 mm - 1/32"	250	14 bolsas / 3.500 uds. caja	16
913020		500	7 bolsas / 3.500 uds. caja	16
913914		100	35 bolsas / 3.500 uds. caja	16
913921	Base 1,5 mm - 1/16"	250	14 bolsas / 3.500 uds. caja	16
913938		500	7 bolsas / 3.500 uds. caja	16
913037		100	35 bolsas / 3.500 uds. caja	16
913044	Base 2 mm - 3/32"	250	14 bolsas / 3.500 uds. caja	16
913051		500	7 bolsas / 3.500 uds. caja	16
913068		100	35 bolsas / 3.500 uds. caja	16
913075	Base 3 mm - 1/8"	250	14 bolsas / 3.500 uds. caja	16
913082		500	7 bolsas / 3.500 uds. caja	16
912641		100	35 bolsas / 3.500 uds. caja	16
912658	Base 4 mm - 5/32"	250	14 bolsas / 3.500 uds. caja	16
912665		500	7 bolsas / 3.500 uds. caja	16
912672		100	35 bolsas / 3.500 uds. caja	16
912689	Base 5 mm - 3/16"	250	14 bolsas / 3.500 uds. caja	16
912696		500	7 bolsas / 3.500 uds. caja	16

H: 16-22MM
BASE ALTA
HIGH BASE
HAUTE BRIDE



CÓDIGO CODE	MEDIDAS SIZES / MESURES	UDS. BOLSA UNITS BAG / UNITÉS SACHET	UDS. CAJA UNITS PACK / UNITÉS PACK	CAJAS PALET PACKS PALLET
913341	1 mm - 1/32"	250	12 bolsas / 3.000 uds. caja	16
913372	2 mm - 3/32"	250	12 bolsas / 3.000 uds. caja	16

*Para otras medidas (3-5mm), consultar.

*For other measurements (3-5mm), consult.

*Pour d'autres mesures (3-5mm), consulter.



CONSTRUCCIÓN
BUILD
CONSTRUIRE



H: 3-14MM

BASE SLIM COMPATIBLE CON ROSCA / CUÑA (ESTRECHA)
SLIM BASE COMPATIBLE WITH LEVELLING THREAD /SLIM WEDGE
SLIM BRIDE COMPATIBLE AVEC FILETAGE / CALE SLIM

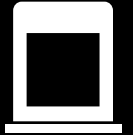

CÓDIGO CODE	MEDIDAS SIZES / MESURES	UDS. BOLSA UNITS BAG / UNITÉS SACHET	UDS. CAJA UNITS PACK / UNITÉS PACK	CAJAS PALET PACKS PALLET
913518		100	30 bolsas / 3.000 uds. caja	16
913525	Base 0,5 mm - 1/64"	250	12 bolsas / 3.000 uds. caja	16
913532		500	6 bolsas / 3.000 uds. caja	16
913099		100	30 bolsas / 3.000 uds. caja	16
913105	Base 1 mm - 1/32"	250	12 bolsas / 3.000 uds. caja	16
913112		500	6 bolsas / 3.000 uds. caja	16
913129		100	30 bolsas / 3.000 uds. caja	16
913136	Base 1,5 mm - 1/16"	250	12 bolsas / 3.000 uds. caja	16
913143		500	6 bolsas / 3.000 uds. caja	16
913150		100	30 bolsas / 3.000 uds. caja	16
913167	Base 2 mm - 3/32"	250	12 bolsas / 3.000 uds. caja	16
913174		500	6 bolsas / 3.000 uds. caja	16
913181		100	30 bolsas / 3.000 uds. caja	16
913198	Base 3 mm - 1/8"	250	12 bolsas / 3.000 uds. caja	16
913204		500	6 bolsas / 3.000 uds. caja	16



H: 3-14 MM

BASE COMPATIBLE CON ROSCA / CUÑA
BASE COMPATIBLE WITH LEVELLING WEDGE / THREAD
BASE COMPATIBLE AVEC CALE / FILETAGE

CÓDIGO CODE	MEDIDAS SIZES / MESURES	UDS. BOLSA UNITS BAG / UNITÉS SACHET	UDS. CAJA UNITS PACK / UNITÉS PACK	CAJAS PALET PACKS PALLET
913549		100	30 bolsas / 3.000 uds. caja	16
913556	Base 0,5 mm - 1/64"	250	12 bolsas / 3.000 uds. caja	16
913563		500	6 bolsas / 3.000 uds. caja	16
913211		100	30 bolsas / 3.000 uds. caja	16
913228	Base 1 mm - 1/32"	250	12 bolsas / 3.000 uds. caja	16
913235		500	6 bolsas / 3.000 uds. caja	16
913242		100	30 bolsas / 3.000 uds. caja	16
913259	Base 1,5 mm - 1/16"	250	12 bolsas / 3.000 uds. caja	16
913266		500	6 bolsas / 3.000 uds. caja	16
913273		100	30 bolsas / 3.000 uds. caja	16
913280	Base 2 mm - 3/32"	250	12 bolsas / 3.000 uds. caja	16
913297		500	6 bolsas / 3.000 uds. caja	16
913303		100	30 bolsas / 3.000 uds. caja	16
913310	Base 3 mm - 1/8"	250	12 bolsas / 3.000 uds. caja	16
913327		500	6 bolsas / 3.000 uds. caja	16

3.1.2. CRUCETAS TILE SPACER CROISILLONS

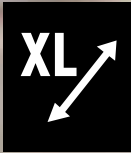
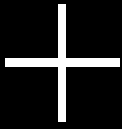

Modo de uso
Mode of use
Mode d'utilisation



910005

910012

910029

910036

910043

910050

910067

910074

910081

912009

CÓDIGO CODE	MEDIDAS SIZES MESURES	UDS. BOLSA UNITS BAG UNITÉSSACHET	UDS. CAJA UNITS PACK UNITÉS PACK	CAJAS PALET PACKS PALLET
910005	1 mm - 1/32"	500	60 bolsas / 30.000	30
910012	1,5 mm - 1/16"	500	60 bolsas / 30.000	30
910029	2 mm - 3/32"	500	60 bolsas / 30.000	20
910036	3 mm - 1/8"	500	60 bolsas / 30.000	20
910043	4 mm - 5/32"	300	45 bolsas / 13.500	20
910050	5 mm - 3/16"	300	45 bolsas / 13.500	20
910067	7 mm - 9/32"	300	20 bolsas / 6.000	20
910074	10 mm - 13/32"	100	30 bolsas / 3.000	20
910081	15 mm - 19/32"	100	12 bolsas / 1.200	42
912009	Cuña 1-5 mm	300	100 bolsas / 30.000	30



3.1.3. KIT SISTEMA DE NIVELACIÓN LEVELLING SYSTEM KIT TÈME DE NIVELLEMENT

CONSTRUCCIÓN
BUILD
CONSTRUIRE



PROFESIONAL

*Para otras medidas, consultar.
*For other measurements, consult.
*Pour d'autres mesures, consulter.



CÓDIGO CODE	MEDIDAS SIZES MESURES	CONTIENE CONTAINED / CONTIENT	UDS. CAJA UNITS PACK UNITÉS PACK
913877	1 mm - 1/32"	Capazo 42L + 750 bases+ 250 cuñas + Alicata metálico Fix collar 42L + 750 bases + 250 wedges + metalic plier Seau de chantier 42L + 750 bases + 250 Cales + pince métallique	1

3.1.4. TAYG PRO TAYG PRO TAYG PRO



CÓDIGO CODE	MEDIDAS SIZES MESURES	UDS. CAJA UNITS PACK UNITÉS PACK	CAJAS PALET PACKS PALLET	CÓDIGO CODE	MEDIDAS SIZES MESURES	UDS. CAJA UNITS PACK UNITÉS PACK	CAJAS PALET PACKS PALLET
912702	Base 0,5 mm - 1/64"	1.000	54	912801	Base 0,5 mm - 1/64"	4.000	20
912719	Base 1 mm - 1/32"	1.000	54	912818	Base 1 mm - 1/32"	4.000	20
912726	Base 1,5 mm - 1/16"	1.000	54	912825	Base 1,5 mm - 1/16"	4.000	20
912733	Base 2 mm - 3/32"	1.000	54	912832	Base 2 mm - 3/32"	4.000	20
912740	Base 3 mm - 1/8"	1.000	54	912849	Base 3 mm - 1/8"	4.000	20
912757	Base 4 mm - 5/32"	1.000	54	912856	Base 4 mm - 5/32"	4.000	20
912764	Base 5 mm - 3/16"	1.000	54	912863	Base 5 mm - 3/16"	4.000	20

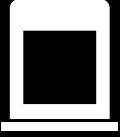

MODO DE USO

Mode of use / Comment utiliser

En primer lugar limpiar la superficie para una correcta colocación, además de ajustar el alicate según el espesor del material.

First clean the surface for correct placement, furthermore adjust the pliers according to the thickness.

Commencez par nettoyer la surface pour une pose correcte, puis ajuster la pince selon l'épaisseur du carrelage.

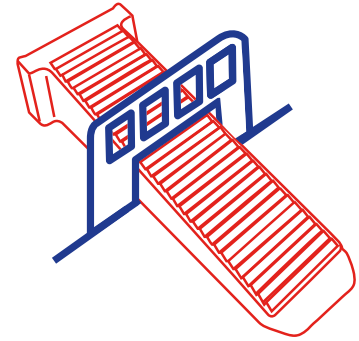

Modo de uso
Mode of use
Mode d'utilisation



1. Colocar bases / Place the base / Placer les bases



2. Macear ligeramente / Tap gently / Taper légèrement



3. Introducir cuñas / Introduce the wedges / Introduire les cales



4. Apretar / Tighten / Serrer

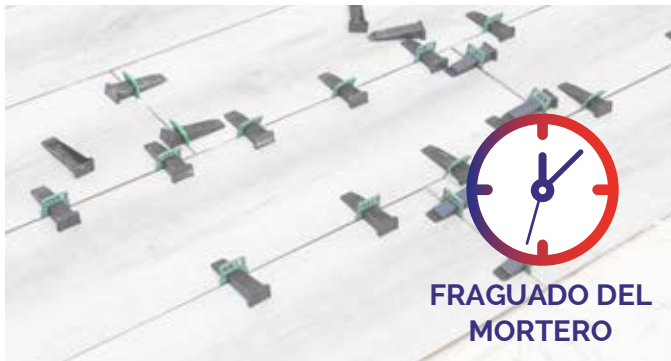

FRAGUADO DEL
MORTERO

5. Esperar secado / Allow for setting / Attendre que cela sèche



6. Retirar sistema / Remove the system / Retirer le système

3.1.5. ACCESORIOS DE NIVELACIÓN LEVELLING SYSTEM ACCESSORIES ACCESSOIRES DE MISE À NIVEAU

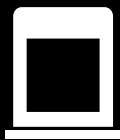

CUÑA SLIM (ESTRECHA) MILIMETRADA 13MM SLIM WEDGE MEASURING (SLIM) 13 MM CALE SLIM MILIMÈTREE (ÉTROITE) 13 MM

CÓDIGO CODE	UDS. BOLSA UNITS BAG / UNITÉS SACHET	UDS. CAJA UNITS PACK / UNITÉS PACK	CAJAS PALET PACKS PALLET
913396	100	20 bolsas / 2.000 uds.caja	16
913402	250	8 bolsas / 2.000 uds. caja	16
913419	500	4 bolsas / 2.000 uds. caja	16



CUÑA PROFESIONAL MILIMETRADA 22MM PROFESSIONAL MEASURING WEDGE 22MM CALE PROFESSIONNELLE MILIMÈTREE 22MM

CÓDIGO CODE	UDS. BOLSA UNITS BAG / UNITÉS SACHET	UDS. CAJA UNITS PACK / UNITÉS PACK	CAJAS PALET PACKS PALLET
913426	100	20 bolsas / 2.000 uds.caja	16
913433	250	8 bolsas / 2.000 uds. caja	16
913440	500	4 bolsas / 2.000 uds. caja	16



ROSCA / THREAD / ÉCROU

CÓDIGO CODE	UDS. BOLSA UNITS BAG / UNITÉS SACHET	UDS. CAJA UNITS PACK / UNITÉS PACK	CAJAS PALET PACKS PALLET
913495	50	24 bolsas / 1.200 uds. caja	16
913501	100	12 bolsas / 1.200 uds. caja	16



3.1.6. TAYG ROLL TAYG ROLL TAYG ROLL

CONSTRUCCIÓN
BUILD
CONSTRUIRE

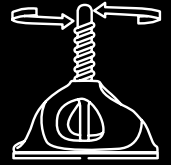

BASE TAYG ROLL / TAYG ROLL BASE / BASE TAYG ROLL

CÓDIGO CODE	MEDIDAS SIZES / MESURES	UDS. BOLSA UNITS BAG / UNITÉS SACHET	UDS. CAJA UNITS PACK / UNITÉS PACK	CAJAS PALET PACKS PALLET
915208	Base 1 mm - 1/32"	200	20 bolsas / 4.000 uds. caja	20
915215	Base 1,5 mm - 1/16	200	20 bolsas / 4.000 uds. caja	20
915222	Base 2 mm - 3/32"	200	20 bolsas / 4.000 uds. caja	20
915239	Base 3 mm - 1/8"	200	20 bolsas / 4.000 uds. caja	20



ROSCA TAYG ROLL / TAYG ROLL THREAD / FILETAGE TAYG ROLL

CÓDIGO CODE	UDS. BOLSA UNITS BAG / UNITÉS SACHET	UDS. CAJA UNITS PACK / UNITÉS PACK	CAJAS PALET PACKS PALLET
915246	100	15 bolsas / 1.500 uds. caja	20



PROTECTOR TAYG ROLL / TAYG ROLL PROTECTOR / PROTECTEUR TAYG ROLL

CÓDIGO CODE	UDS. BOLSA UNITS BAG / UNITÉS SACHET	UDS. CAJA UNITS PACK / UNITÉS PACK	CAJAS PALET PACKS PALLET
915253	100	50 bolsas / 5.000 uds. caja	16



KIT TAYG ROLL / TAYG ROLL KIT / KIT TAYG ROLL

CÓDIGO CODE	MEDIDAS SIZES / MESURES	CONTIENE CONTAINS / CONTIENT	UDS. CAJA UNITS PACK / UNITÉS PACK	CAJAS PALET PACKS PALLET
915307	Base 1 mm - 1/32"		6 bolsas / bags / sachets	20
915314	Base 1,5 mm - 1/16	200 bases + 100 roscas + 100 protectores	6 bolsas / bags / sachets	20
915321	Base 2 mm - 3/32"	200 bases + 100 thread + 100 protectors	6 bolsas / bags / sachets	20
915338	Base 3 mm - 1/8"	200 bases + 100 filetage + 100 protecteurs	6 bolsas / bags / sachets	20

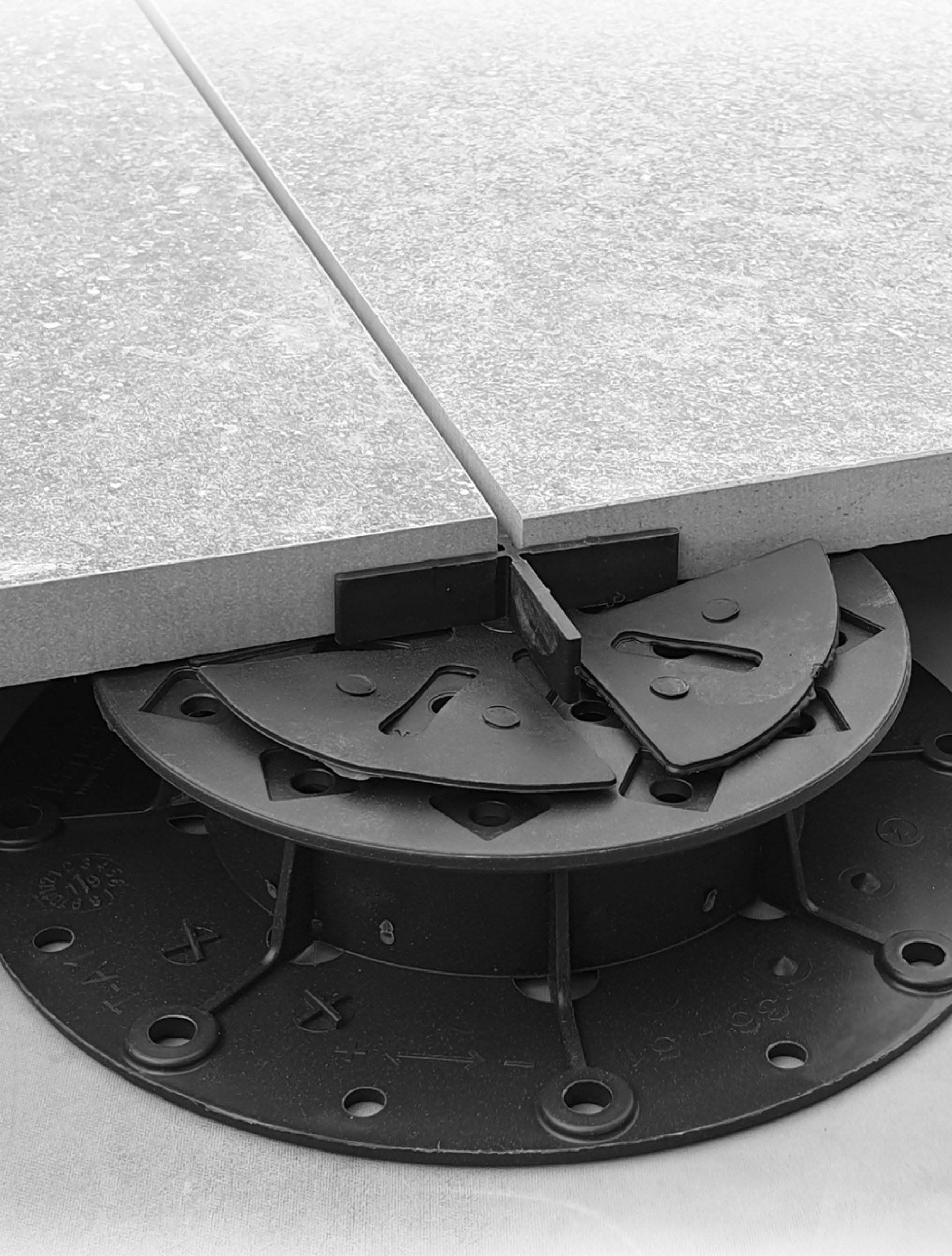

3.2 **SOPORTES PARA SUELOS ELEVADOS** **SUPPORTS FOR ELEVATED FLOORS** **SUPPORTS POUR SOLS SURÉLEVÉS**

3.2.1. SUELO FLOTANTE 140
FLOATING FLOOR
PLANCHER FLOTTANT

3.2.2. PLOTS FIJOS 145
FIXED PEDESTALS
PLOTS FIXES

3.2.3. PLOTS REGULABLES 146
ADJUSTABLE PEDESTALS
PLOTS REGABLES

3.2.4. ACCESORIOS GENERALES 148
GENERAL ACCESSORIES
ACCESSOIRES GÉNÉRAUX

3.2.5. OTROS ACCESORIOS 150
OTHER ACCESSORIES
AUTRES ACCESSORIES



SISTEMA DE SUELOS ELEVADOS RAISED FLOORING SYSTEM SYSTÈME DE PLANCHER SURÉLEVÉ



BENEFICIOS Y CARACTERÍSTICAS ADVANTAGES AND CHARACTERISTICS AVANTAGES ET CARACTÉRISTIQUES



- El agua que se filtra del terreno en las zonas ajardinadas se puede eliminar fácilmente
Water seeping from the ground into the landscaped areas can be easily removed
L'eau qui s'infiltré du sol dans les zones aménagées peut être facilement éliminée

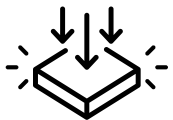

- Alta resistencia a la carga
High load resistance
Résistance élevée à la charge



- Fácil y rápido
Easy and quick
Facile et rapide



- Sistema de autonivelación
Self-levelling system
Système d'auto-nivellement

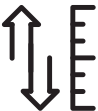

- Puede ajustarse a la altura especificada en el proyecto
Can be adjusted to the height specified in the project
Peut être ajusté à la hauteur spécifiée dans le projet



- Elimina las diferencias de la pendiente
Eliminates slope differences
Élimine les différences de pente



- Se puede utilizar por debajo de un suelo temporal
Can be used under a temporary floor
Peut être utilisé sous un plancher temporaire



- Se puede aplicar en todas las condiciones meteorológicas
Can be applied in all weather conditions
Peut être appliqué dans toutes les conditions météorologiques



- Puede instalarse sobre suelo resistente al agua o sobre aislamiento térmico
Can be installed on water-resistant flooring or on thermal insulation
Peut être installé sur un revêtement de sol résistant à l'eau ou sur une isolation thermique



- La iluminación, el cableado, los accesorios y la circulación del agua pueden realizarse bajo el sistema elevado
Lighting, wiring, fittings and water circulation can be carried out under the elevated system
L'éclairage, le câblage, l'aménagement et la circulation de l'eau peuvent être réalisés sous le système surélevé



PLOTS
PEDESTALS
PLOTS



ÁREAS DE APLICACIÓN
APPLICATION AREAS
DOMAINES D'APPLICATION

Terrazas, salas eléctricas, recinto ferial, zonas ajardinadas, piscinas, polígonos industriales, balcones
Terraces, electrical halls, fairgrounds, garden areas, swimming pools, industrial estates, balconies
Terrasses, halls électriques, champs de foire, zones de jardin, piscines, zones industrielles, balcons

MATERIALES DE PAVIMENTACIÓN
PAVING MATERIALS
MATÉRIAUX UTILISABLES SUR PLOTS

Tablero de aglomerado, cerámica, mármol, piedra natural, granito, composite Deck, tarima de madera.
Chipboard, ceramic, marble, natural stone, granite, composite deck, wooden decking.
Panneau de particules, céramique, marbre, pierre naturelle, granit, terrasse composite, terrasse en bois.



3.2.1. SUELO FLOTANTE FLOATING FLOOR PLANCHER FOTTANT



CÓDIGO CODE	DESCRIPCIÓN DESCRIPTION	UDS. CAJA UNITS PACK / UNITÉS PACK	CAJAS PALET PACKS PALLET
----------------	----------------------------	---------------------------------------	-----------------------------

915130	500x500x40mm	4	-
--------	--------------	---	---

915130

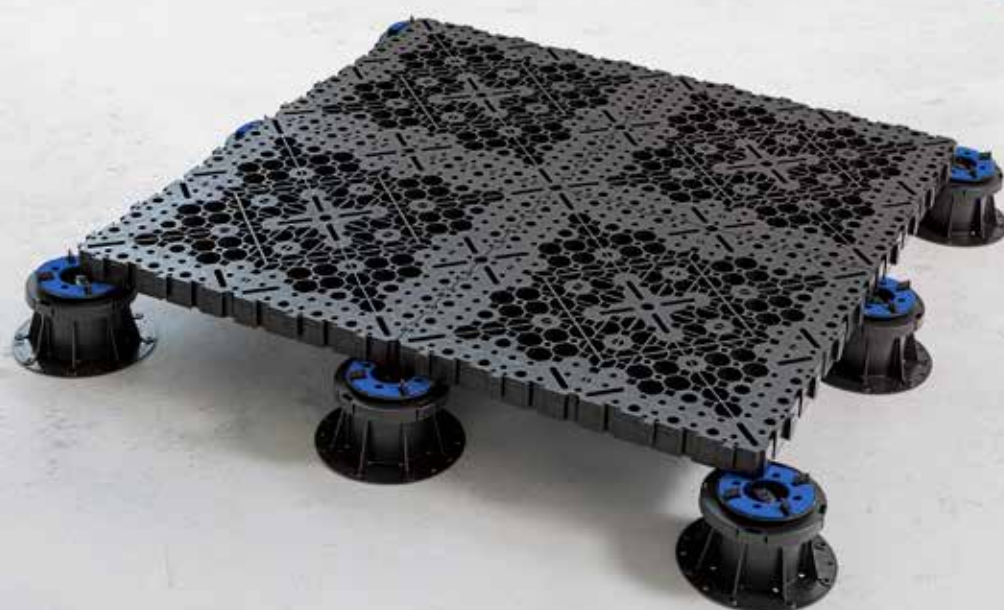

El sistema PARRILLA SUELO FLOTANTE usa paneles modulares de 50×50×4 cm en material termoplástico resistente que encajan entre sí para formar una base elevada y estable. Se instala sobre plots regulables fijados en las esquinas con espaciadores. Incluye cabezales autonivelantes para garantizar una superficie plana incluso en suelos irregulares.

The PARRILLA RAISED FLOOR system uses 50×50×4 cm thermoplastic modular panels that interlock to form a stable elevated base. It installs on height-adjustable pedestals fixed at the corners with spacers. Self-levelling heads ensure a perfectly flat surface even on uneven substrates.

Le système de PLANCHER SURÉLEVÉ PARRILLA utilise des panneaux modulaires de 50×50×4 cm en matériau thermoplastique qui s'assemblent pour former une base élevée et stable. Il s'installe sur des plots réglables en hauteur, fixés aux coins avec des entretoises. Des têtes auto-nivelantes garantissent une surface parfaitement plane, même sur des supports irréguliers.

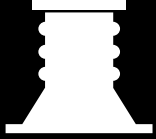

3.2.1. SUELO FLOTANTE FLOATING FLOOR PLANCHER FOTTANT



915147 - 915154 Se combinan con todos los plots ajustables

915147 - 915154 These are compatible with all adjustable pedestals.

915147 - 915154 Il est compatible avec tous les plots réglables.

ACCESORIOS / ACCESSORIES / ACCESSOIRES



CABEZA AUTONIVELANTE
BIMATERIAL 3MM

915147



CABEZA FIJA
BIMATERIAL 3MM

915154

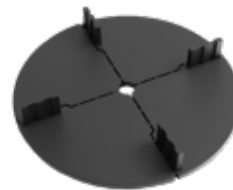

DISCO SEPARADOR
BALDOSAS 3MM

915178

CÓDIGO CODE	DESCRIPCIÓN DESCRIPTION	UDS. CAJA UNITS PACK UNITÉS PACK	CAJAS PALET PACKS PALLET
915147	Cabeza autonivelante bimaterial 3mm	24	
915154	Cabeza fija bimaterial 3mm	24	-
915178	Disco separador baldosas 3mm	24	



Seguridad como prioridad: crea una plataforma elevada y robusta que actúa como barrera protectora.

Safety-focused design: creates a raised, robust platform that acts as a protective barrier.

Conception axée sur la sécurité: crée une plateforme surélevée et robuste qui agit comme barrière protectrice.



Contención de fragmentos: si el revestimiento superior se rompe, los restos quedan retenidos, evitando cortes o caídas.

Fragment containment: if the top surface breaks, fragments remain contained, preventing cuts or tripping hazards.

Rétention des fragments: si le revêtement supérieur se casse, les débris restent contenus, évitant coupures et risques de chute.



Adecuado para exteriores: pensado para espacios donde se requieren seguridad, estabilidad y flexibilidad de diseño.

Ideal for outdoor use: designed for areas requiring safety, stability, and flexible design options.

Idéal pour l'extérieur: conçu pour les espaces nécessitant sécurité, stabilité et flexibilité de design.



QUICK AND EASY INSTALLATION IN 4 STEPS

1. Distribute the adjustable pedestals across the surface and adjust their height to the desired level.
2. Place the panels on top of the pedestals, fitting them together using the joints.
3. Check that the entire surface is level.
4. Install the final covering using the appropriate spacers to maintain uniform joints and precise alignment.

INSTALLATION RAPIDE ET SIMPLE EN 4 ÉTAPES

1. Répartissez les plots réglables sur la surface et ajustez leur hauteur au niveau souhaité.
2. Placez les panneaux sur les plots en les emboîtant à l'aide des joints.
3. Vérifiez que l'ensemble de la surface soit bien de niveau.
4. Installez le revêtement final en utilisant les entretoises appropriées pour conserver des joints réguliers et un alignement précis.

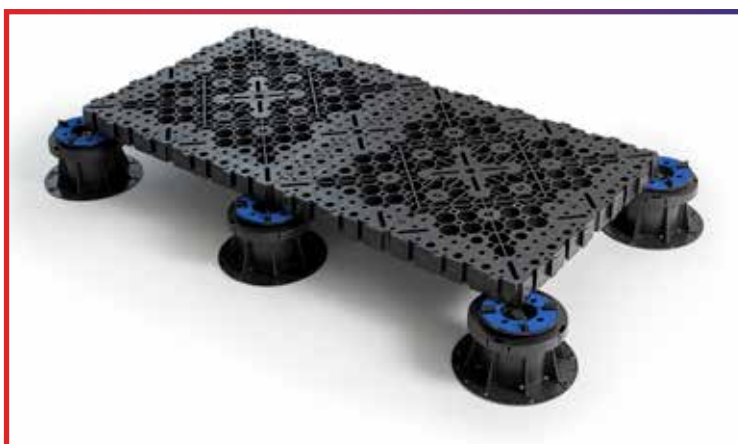
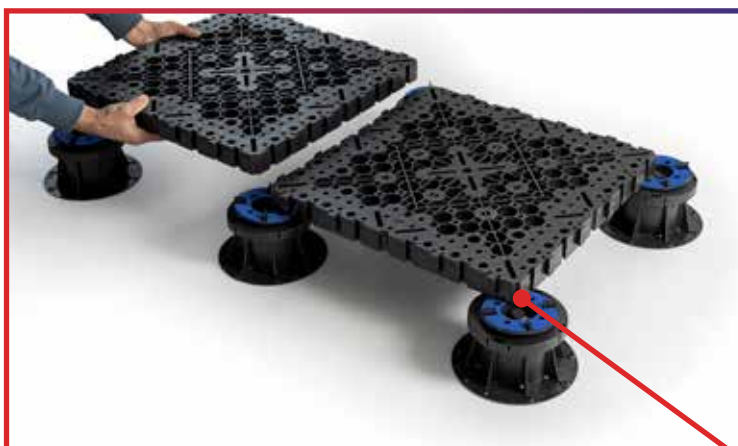

INSTALACIÓN RÁPIDA Y SENCILLA EN 4 PASOS

1. Distribuye los plots ajustables sobre la superficie y adapta su altura al nivel deseado.
2. Coloca los paneles sobre los plots, encajándolos entre sí mediante las juntas.
3. Verifica que toda la superficie esté nivelada.
4. Instala el revestimiento final utilizando los espaciadores adecuados para mantener juntas uniformes y un alineado preciso.

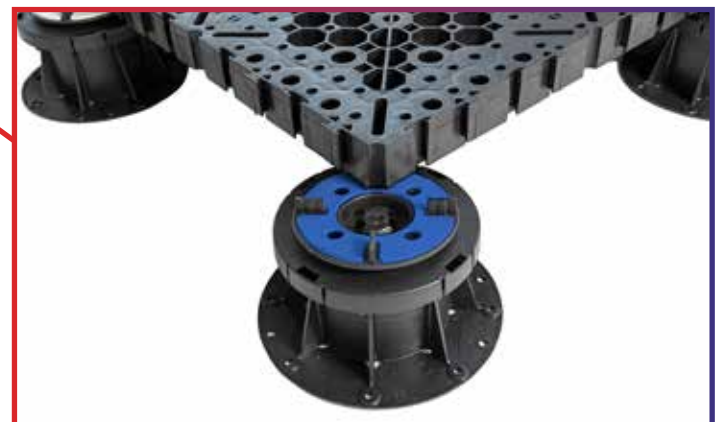
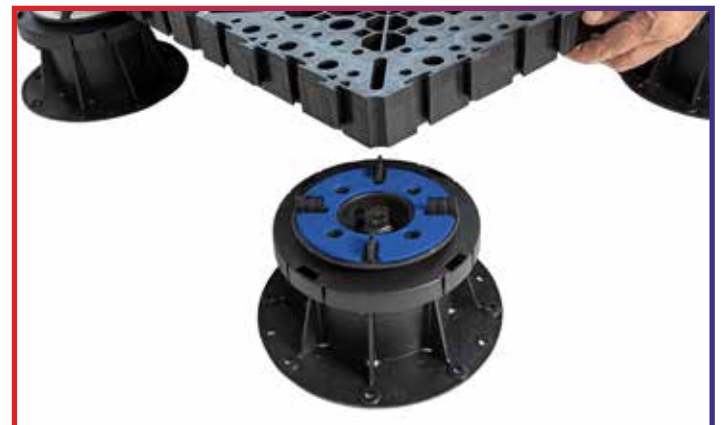



CÁLCULO PLOTS (SOPORTE ELEVADOS) PARA BALDOSAS
PEDESTAL CALCULATOR
CALCULATEUR DE PLOTS

	MEDIDAS BALDOSA CM TILE SIZES MESURES DE CARREAUX	Nº PLOTS/M ² Nº PEDESTALS/M ²	CON PLOTS CENTRALES WITH CENTRAL PEDESTALS AVEC PLOTS CENTRALES
EJEMPLO CÁLCULO:			
AREA: 50 m ²	30 x 30	12,5 uds	
BALDOSA: 60 X 60 cm = 3,4 u.	30 x 60	6,5 uds	
PLOTS: 50 m ² X 3,4 u = 170 u.	40 x 40	6,9 uds	
	45 x 45	6,9 uds	
	40 x 60	4 uds	
EXAMPLE CALCULATION:			
AREA: 50 m ²	50 x 50	4,5 uds	
TILE: 60 X 60 cm = 3,4 u.	60 x 60	3,4 uds	6,3 uds
PEDESTAL: 50 m ² X 3,4 u = 170 u.	75 x 75	2,3 uds	4,3 uds
	80 x 80	2 uds	3,7 uds
	45 x 90		5,8 uds
EXEMPLE DE CALCUL:			
SURFACE: 50 m ²	90 x 90	1,7 uds	3,1 uds
CARREAUX: 60 X 60 cm = 3,4 u.	100 x 100		4,5 uds
PLOTS: 50 m ² X 3,4 u = 170 u.	30 x 120		6,4 uds
	40 x 120		4,8 uds
	60 x 120		3,4 uds

3.2.2. PLOTS FIJOS FIXED PEDESTALS PLOTS FIXES

PLOTS
PEDESTALS
PLOTS

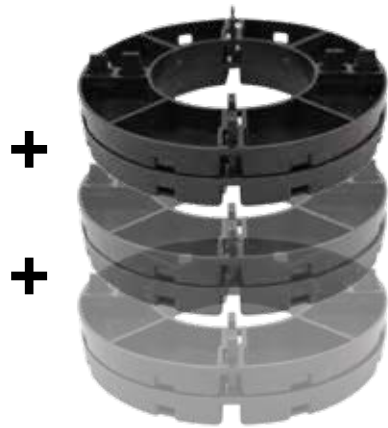

+
+

APILABLES
STACKABLES
EMPILABLE



914829

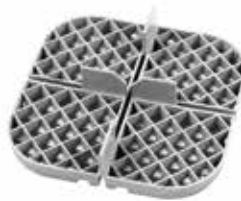

914836



914843



914850

MODELO MODEL / MODÈLE	CÓDIGO CODE	MEDIDAS SIZES / MESURES	UDS. CAJA UNITS PACK / UNITÉS PACK	CAJAS PALET PACKS PALLET
TBF-14	914829	14 mm - 0,55in	260	16
TBF-16	914836	16 mm - 0,63in (tamaño pestaña)	150	16
TBF-20	914843	20 mm - 0,79in	180	12
TBF-30	914850	30 mm - 1,18in	120	12



3.2.3. PLOTS REGULABLES ADJUSTABLE PEDESTALS PLOTS REGABLES

TBR-1825
914607
18-25mm
0,71-0,98in



TBR-2840
914614
28-40mm
1,10-1,42in

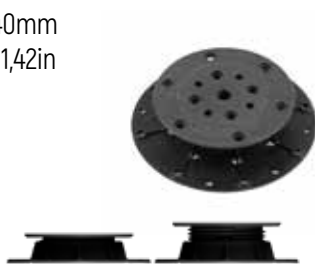

TBR-3651
914621
36-51mm
1,42-2,05in



TBR-5282
914638
52-82mm
2,05-3,23in



TBR-83134
914645
83-134mm
3,23-5,32in



TBR-133225
914652
133-225mm
5,23-8,86in



MODELO MODEL / MODÈLE	CÓDIGO CODE	MEDIDAS SIZES / MESURES	UDS. CAJA UNITS PACK / UNITÉS PACK	CAJAS PALET PACKS PALLET
TBR-1825	914607	18-25 mm	132	16
TBR-2840	914614	28-40 mm	90	16
TBR-3651	914621	36-51 mm	60	16
TBR-5282	914638	52-82 mm	48	16
TBR-83134	914645	83-134 mm	24	16
TBR-133225	914652	133-225 mm	24	16



TBR-189293

914904

189-293 mm

7,44-11,54in



TBR-260365

914911

260-365 mm

10,24-14,37in



TBR-364507

914928

364-507 mm

14,33-19,96in



TBR-471651

914935

471-651 mm

18,54-25,63in



TBR-576795

914942

576-795 mm

22,68-31,30in



TBR-682939

914959

682-939 mm

26,85-36,97in



TBR-7861083

914966

786-1083 mm

30,95-42,64in



MODELO MODEL MODÈLE	CÓDIGO CODE	MEDIDAS SIZES MESURES	Nº ADAPTADORES ADAPTERS UNITS NOMBRE D'ADAPTATEURS	UDS. CAJA UNITS PACK UNITÉS PACK	MONTAJE ASSEMBLY ASSEMBLAGE	PACKING
TBR-189293	914904	189-293 mm	TB-CL 1	24	TBR-83134 x 1 TB-CL	1 x 914645 - 1 x 914669
TBR-260365	914911	260-365 mm	TB-CL 1	24	TBR-133225 x 1 TB-CL	1 x 914652 - 1 x 914669
TBR-364507	914928	364-507 mm	TB-CL 2	24	TBR-133225 x 2 TB-CL	1 x 914652 - 2 x 914669
TBR-471651	914935	471-651 mm	TB-CL 3	24	TBR-133225 x 3 TB-CL	1 x 914652 - 3 x 914669
TBR-576795	914942	576-795 mm	TB-CL 4	24	TBR-133225 x 4 TB-CL	1 x 914652 - 4 x 914669
TBR-682939	914959	682-939 mm	TB-CL 5	24	TBR-133225 x 5 TB-CL	1 x 914652 - 5 x 914669
TBR-7861083	914966	786-1083 mm	TB-CL 6	24	TBR-133225 x 6 TB-CL	1 x 914652 - 6 x 914669

3.2.4. ACCESORIOS GENERALES GENERAL ACCESSORIES ACCESSOIRES GÉNÉRAUX



Amortiguador
Shock absorber
Amortisseur

914690



Adaptador
Height adapter
Rehausse

914669



Contra tuerca
Back thread
Ecrou de blocage

914683



Disco nivelador
Leveling disc
Disque niveleur

914676

MODELO MODEL / MODÈLE	CÓDIGO CODE	MEDIDAS SIZES/ MESURES	UDS. CAJA UNITS PACK / UNITÉS PACK	CAJAS PALET PACKS PALLET
TB-A	914690	-	40 ud./bolsa - 8 bolsas	-
TB-CL	914669	altura 180mm	24	-
TB-CR	914683	altura 10mm	100	-
TB-DN	914676	desnivel 2%	100	-



914706

Cruceta separador central
Central spacer crosshead
Traverse de séparation centrale



914720

Separador recto
Straight spacer
Séparateur droit

Modo de uso
Mode of use
Mode d'utilisation



914751

Adaptador rastreles
Tracking adapter
Adaptateur à piston



914744

Adaptador rastreles central
Central tracking adapter
Adaptateur à piston central

ACCESORIOS FIJOS
FIXED ACCESSORIES
ACCESSORIES FIXES



MODELO MODEL / MODÈLE	CÓDIGO CODE	MEDIDAS SIZES/ MESURES	UDS. CAJA UNITS PACK / UNITÉS PACK	CAJAS PALET PACKS PALLET
TBF-SC3	914706	3mm - 1/8"	40 ud./bolsa - 13 bolsas	36
TBF-SM3	914720	3mm - 1/8"	40 ud./bolsa - 25 bolsas	-
TBF-W	914751	-	40 ud./bolsa - 11 bolsas	-
TBF-WH	914744	40-50 mm - 1,57-1,97in	32	-

CABEZA AUTONIVELANTE 7% DESNIVEL
SELF-LEVELLING HEAD 7% SLOPE
TÊTE AUTONIVELANTE 7% DE DENIVELEMENT

3mm - 1/8"



914775

Cabeza baldosa autonivelante
Self-leveling tile head
Tête transversale auto-nivelante



914768

Cabezal central autonivelante
Self-levelling central head
Tête centrale auto-nivelante



914805

Cabezal de viga autonivelante
Self-leveling beam heads
Tête pour lambourdes à nivellement automatique



914799

Cabezal de viga autonivelante
Self-leveling beam heads
Tête pour lambourdes à nivellement automatique

Cabezales autonivelantes +20mm de altura / Self-levelling heads +20mm height / Têtes auto-nivelantes +20mm de hauteur

MODELO MODEL / MODÈLE	CÓDIGO CODE	MEDIDAS SIZES/ MESURES	UDS. CAJA UNITS PACK / UNITÉS PACK	CAJAS PALET PACKS PALLET
TBR-TS3	914775	3mm - 1/8"	24	96
TBR-C	914768	Plano	28	96
TBR-WH	914805	Vigas de hasta Beams up to / Poutres jusqu'à 40-50 mm - 1,57-1,97in	20	-
TBR-WHS	914799	Vigas de hasta Beams up to / Poutres jusqu'à 80 mm - 3,15in	20	-

3.2.5. OTROS ACCESORIOS OTHER ACCESSORIES AUTRES ACCESORIES



Tornillo fijación viento
Central fixing screw
Vis de fixation vent

TB-PV 914867



Separador pared
Wall separator
Séparateur mural

TB-SP 914812



Clip metal arriba
Metal clip on top
Clip métallique en haut

TB-MTF 914881



Clip metal abajo
Metal clip at bottom
Clip métal en le bas

TB-MBF 914898



Llave ajustable
Height adjustable key
Clé de réglable

TBR-AK 914874



Hta. taladro
Adapter tool for drill
Outil de forage

TBR-AT 914973

MODELO MODEL / MODÈLE	CÓDIGO CODE	UDS. CAJA UNITS PACK / UNITÉS PACK
TB-PV	914867	100 ud./bolsa - 5 bolsas
TB-SP	914812	100
TB-MTF	914881	100
TB-MBF	914898	100
TBR-AK	914874	2
TBR-AT	914973	2

TB-SP



Se puede utilizar con todos nuestros plots. Crea un hueco entre el plot y la pared permitiendo un flujo de agua perfecto, incluso en condiciones meteorológicas adversas (lluvias intensas, nieve, etc.).

Can be used with all our pedestals. It creates a gap between the pedestal and the wall allowing a perfect water flow, even in adverse weather conditions (heavy rain, snow, etc.).

Peut être utilisé avec tous nos Plots. Il crée un espace entre le plot et le mur, ce qui permet un écoulement parfait de l'eau, même en cas de mauvaises conditions météorologiques (fortes pluies, neige, etc.).

TBR-AK

Herramienta. Llave ajustable. Con esta llave conseguimos regular la altura con la cabeza autonivelante. Se puede usar en la instalación finalizada o en el momento de la colocación de las baldosas.

With this key we can adjust the height of the self-levelling head. It can be used during final assembly or when laying tiles.

Cette clé permet de régler la hauteur de la tête autonivelante. Elle peut être utilisée lors du montage final ou lors de la pose de carreaux.



TB-PV



Protector contra el viento que evita que el pavimento se levante en caso de fuertes vientos.

Wind protector that prevents the pavement from lifting in strong winds.

Protection contre le vent qui empêche le sol de se soulever en cas de vents forts.



TB-MTF / TB-MBF

Accesorio metálico terminación lateral.

Metal fitting with vertical end edge clamp.

Raccord métallique avec terminaison latérale.





TABLA CÁLCULO PLOTS POR M²

TABLE CALCULATION PEDESTALS PER M²

TABLEAU CALCUL PLOTS PAR M²

	20	30	40	45	50	60	70	75	80	90	100
20	25	16,67	12,5	11,11	10	8,33	14,29	13,33	12,5	11,11	10
30	16,67	11,11	8,33	7,41	6,67	5,56	9,52	8,89	8,33	7,41	6,67
40	12,5	8,33	6,5	5,56	5	4,17	7,14	6,67	6,65	5,56	5
45	11,1	7,41	5,56	4,94	4,44	3,7	6,35	5,63	5,56	4,94	4,44
50	10	6,67	5	4,44	4	3,33	5,71	5,33	5	4,44	4
60	8,3	5,56	4,17	3,7	3,33	3,78	4,76	4,44	4,17	3,7	3,33
70	14,29	9,52	7,14	6,35	5,71	4,76	4,08	3,81	3,57	3,17	2,86
75	13,33	8,89	6,67	5,93	5,33	4,44	3,81	3,56	3,33	2,96	2,67
80	12,5	8,33	6,25	5,56	5	4,17	3,57	3,33	6,25	5,56	5
90	11,11	7,41	5,56	4,94	4,44	3,7	3,17	2,96	5,56	4,94	4,44
100	10	6,67	5	4,44	4	3,33	2,86	2,67	5	4,44	4
120	8,33	5,56	4,17	3,7	3,33	2,78	2,38	2,22	4,17	3,7	3,33
140	14,29	9,52	7,14	6,35	5,71	4,76	2,04	1,9	3,57	3,17	2,86
160	12,5	8,33	6,25	5,56	5	4,17	3,57	3,33	6,25	5,56	5
180	8,33	5,56	4,17	3,7	3,33	2,78	2,38	2,22	4,17	3,7	3,33

Esta tabla es un cálculo matemático y no tiene en cuenta las variables de la construcción, por lo tanto, es orientativo y se recomienda incrementar el valor entre un 5 y 15%

This table is a mathematical calculation and does not take into account the construction variables, therefore it is indicative and it is recommended to increase the above values by 5 to 15%

Ce tableau est un calcul mathématique et ne prend pas en compte les variables de construction, il est donc indicatif et recommandé d'augmenter la valeur entre 5 et 15%

CÁLCULO POR TAMAÑO DE BALDOSA CALCULATION BY TILE SIZE CALCUL PAR TAILLE DE CARREAUX

CONSTRUCCIÓN
BUILD
CONSTRUIRE

Calculadora de plots
Pedestals calculator
Calculateur de plots

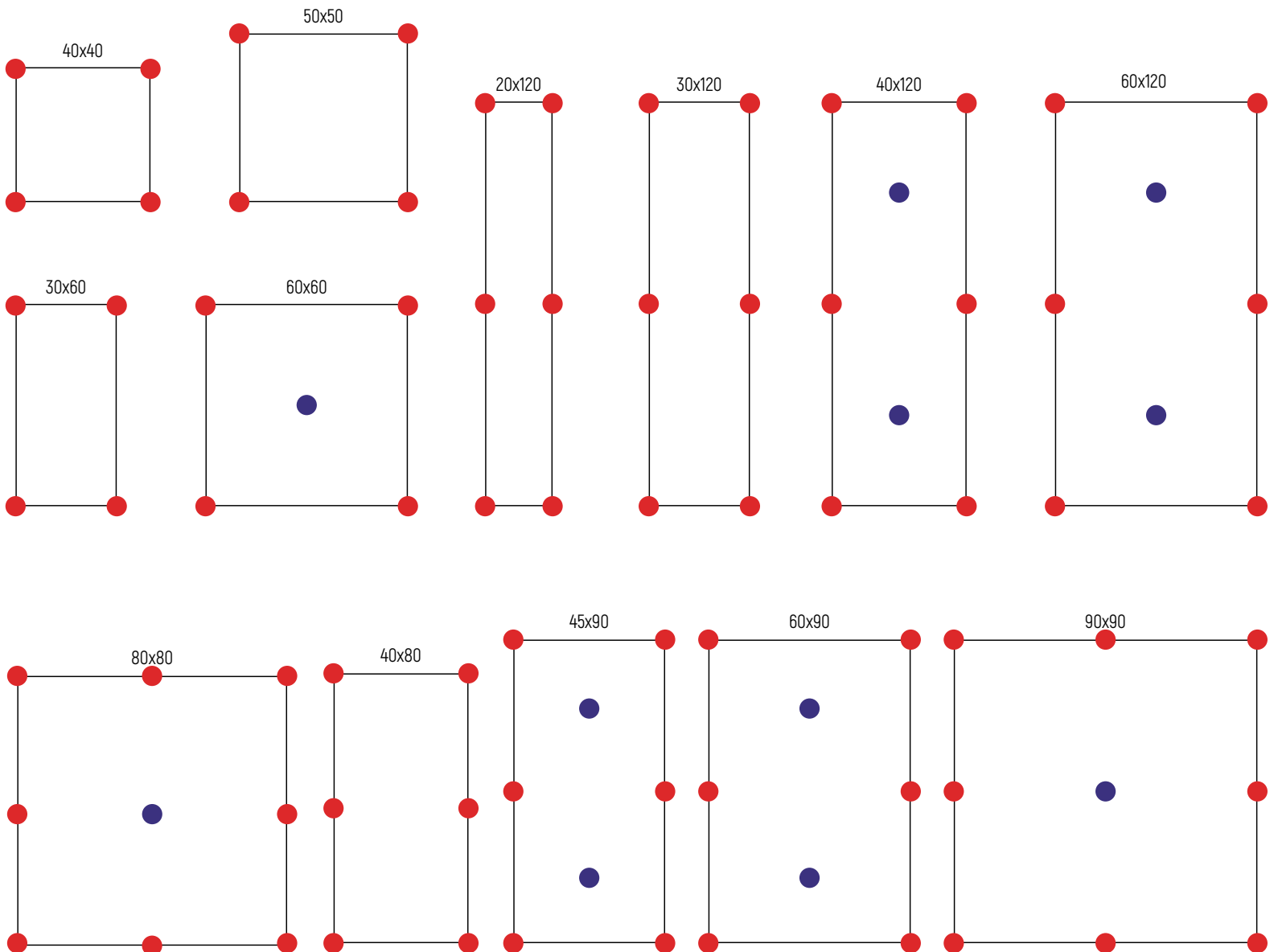



3.3

PAVÉS Y ACCESORIOS DE SEGURIDAD GLASS BLOCK SPACER AND SAFETY ACCESSORIES ENTRETOISE ET ACCESSOIRES DE SÉCURITÉ

3.3.1. DISTANCIADOR BLOQUE DE VIDRIO 156
GLASS-BLOCK TILE SPACERS
CROIX POURR ASSEMBLAGE BRIQUE DE VERRE

3.3.2. SETA PROTECTORA 156
SAFETY CAP
CHAMPIGNOG PROTECTEUR

3.3.3. BASES SEGURIDAD 157
SAFETY BASES
LES BASES DE LA SÉCURITÉ



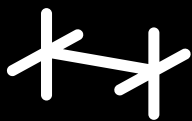

3.3.1. DISTANCIADOR BLOQUE DE VIDRIO GLASS-BLOCK TILE SPACERS CROIX POURR ASSEMBLAGE BRIQUE DE VERRE

CÓDIGO CODE	MEDIDAS SIZES / MESURES	UDS. CAJA UNITS PACK / UNITÉS PACK	CAJAS PALET PACKS PALLET
915000	10 mm	120	55

Los separadores en forma de cruz garantizan la correcta separación de los bloques pavés, con un coste bajo y rapidez de colocación.

The glass-block tile spacers on the cross shape guarantees the correct separation of the glass-block with a low cost and speed of placement.

Les séparateurs en forme de croix assurent une séparation correcte de la brique de verre, avec un bas coût et une pose rapide.

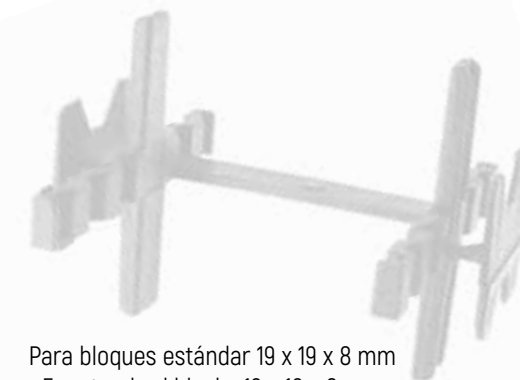

Para bloques estándar 19 x 19 x 8 mm
For standard blocks 19 x 19 x 8 mm
Pour des briques standard 19 x 19 x 8 mm

3.3.2. SETA PROTECTORA SAFETY CAP CHAMPIGNOG PROTECTEUR

Colocación en varilla de acero corrugado saliente. Con su colocación protege al trabajador de las varillas punzantes, en caso de caída o roce. El interior de la pieza está formado por 4 aletas flexibles, para el perfecto anclaje de la varilla.

Placement in protruding corrugated steel rod. With its placement protects the worker from sharp rods, in case of fall or friction. The inside of the piece is formed by 4 flexible fins, for the perfect anchoring of the rod.

Pose sur tige en acier ondulé saillant. Avec son placement protège le travailleur des tiges pointues, en cas de chute ou de frottement. L'intérieur de la pièce est composé de 4 ailettes flexibles, pour l'ancrage parfait de la tige.



Seta protectora "P" (Varilla de 8 a 20 mm)
Safety cap "P" (rod from 8 a 20 mm)
Capuchon protecteur "P" (barre de 8 a 20 mm)

918001

Seta protectora (Varilla de 12 a 20 mm)
Safety cap (rod from 12 a 20 mm)
Capuchon protecteur (barre de 12 a 20 mm)

918018

Seta protectora (Varilla de 24 a 40 mm)
Safety cap (rod from 24 a 40 mm)
Capuchon protecteur (barre de 24 a 40 mm)

918025

CÓDIGO CODE	UDS. BOLSA UNITS BAG / UNITÉS SACHET	UDS. PALET UNITS PALLET / UNITÉS PALLET
918001	250	22.750 - 91 bolsas
918018	250	15.000 - 60 bolsas
918025	150	5.400 - 36 bolsas



3.3.3. BASES SEGURIDAD SAFETY BASES LES BASES DE LA SÉCURITÉ

SEGURIDAD
SAFETY
SÉCURITÉ



Base cajetín línea de vida
Base life line
Base boîte de ligne de vie

918070

Base horcax (valla de seguridad 60x60)
Base horca (safety fence 60x60)
Base horcax (cloture de sécurité 60x60)

918100

CÓDIGO CODE	MEDIDAS SIZES MESURES	UDS. BOLSA UNITS BAG UNITÉS SACHET	UDS. PALET UNITS PALLET UNITÉS PALLET
918070	60 x 40 mm	50	1.800 - 36 bolsas
918100	80 x 80 mm	45 uds. caja	1.080 - 24 cajas

*Tapa incorporada
Built-in lid
Couvercle intégré



Base guardacuerpos "conix"
Conix base
Base garde-corps conix

918049

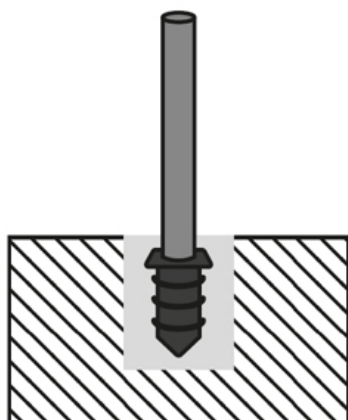

CÓDIGO CODE	MEDIDAS SIZES MESURES	UDS. BOLSA UNITS BAG UNITÉS SACHET	UDS. PALET UNITS PALLET UNITÉS PALLET
918049	40 mm	150	5.250 - 35 bolsas



3.4

ACCESORIOS PARA ENCOFRADO FORMWORK ACCESSORIES ACCESSOIRES POUR COFFRAGE

3.4.1. TUBOS Y CONOS 160
TUBE AND CONE / TUBES ET CÔNES

3.4.2. TAPONES 161
PLUGS / BOUCHONS

3.4.3. TUBO RÁPIDO 161
FAST TUBE / TUYAU RAPIDE

3.4.4. BERENJENO Y JUNTA DILATACIÓN 162
CHAMFER STRIP AND DILATATION JOINT
LITEAU TRIANGULAIRE ET JOINT DE DILATATION

3.4.5. SEPARADORES SIERRA 163
SAW PLASTIC SPACER / SÉPARATEUR SCIE

3.4.6. SEPARADOR CONDOR 163
CONDOR SPACER / SÉPARATEUR CONDOR

3.4.7. SEPARADOR TIMÓN 164
RUDDER SPACER / SÉPARATEUR GOUVERNAIL

3.4.8. SEPARADORES DE HORMIGÓN 165
CONCRETE SPACER / SÉPARATEUR DE BÉTON





3.4.1. TUBOS Y CONOS TUBE AND CONE TUBES ET CÔNES

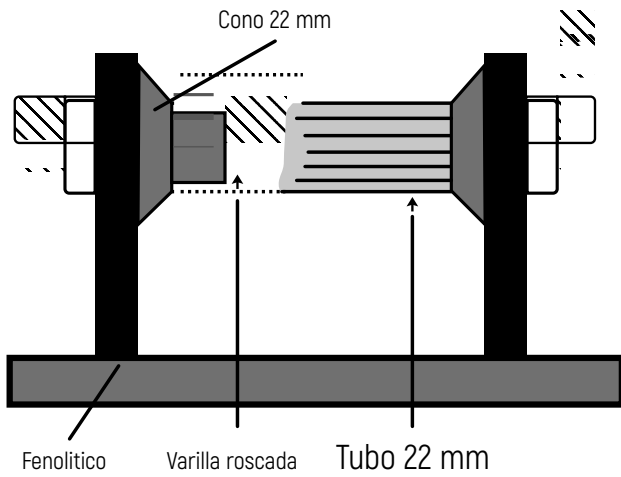

Tubo encofrado - pasamuro \varnothing 22
Formwork tube \varnothing 22
Tuyau de passage de coffrage \varnothing 22

916007



Tubo encofrado - pasamuro \varnothing 26
Formwork tube \varnothing 26
Tuyau de passage de coffrage \varnothing 26

916014



Cono tubos pasamuro \varnothing 22
Bushing cone \varnothing 22
Tubes de passage \varnothing 22

916090



Cono tubos pasamuro \varnothing 26
Bushing cone \varnothing 26
Tubes de passage \varnothing 26

916243

CÓDIGO CODE	MEDIDAS SIZES/ MESURES	UDS. ATADO UNITS / UNITÉS	PAQUETES PALET PALLET PACKAGES / PAQUETS DE PALETTE	UDS. BOLSA UNITS BAG / UNITÉS SACHET	BOLSAS PALET BAGS PALLET / SACS PALLET
916007	\varnothing 22-26 x 2 mts	25	60	-	-
916014	\varnothing 26-30 x 2 mts	20	60	-	-
916090	22 mm	-	-	500	104 bolsas / 52.000 uds
916243	26 mm	-	-	1.000	52 bolsas / 52.000 uds

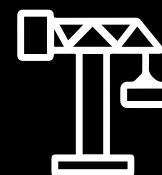

3.4.2. TAPONES PLUGS BOUCHONS



916205

Tapón liso para encofrado Ø22
Flat plug for formwork Ø22
Bouchon lisse pour coffrage Ø22



916151

Tapón liso para encofrado Ø26
Flat plug for formwork Ø26
Bouchon lisse pour coffrage Ø26

CÓDIGO CODE	MEDIDAS SIZES MESURES	UDS. BOLSA UNITS BAG UNITÉS SACHET	UDS. CAJA UNITS PACK UNITÉS PACK	UDS. PALET UNITS PALLET UNITÉS PALLET
916205	22 mm	500	7 bolsas / 3.500	30 cajas / 105.000
916151	26 mm	500	9 bolsas / 4.500	20 cajas / 90.000



3.4.3. TUBO RÁPIDO FAST TUBE TUYAU RAPIDE

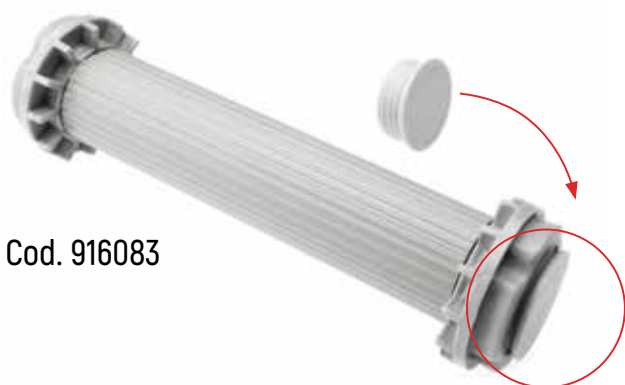

Cod. 916083

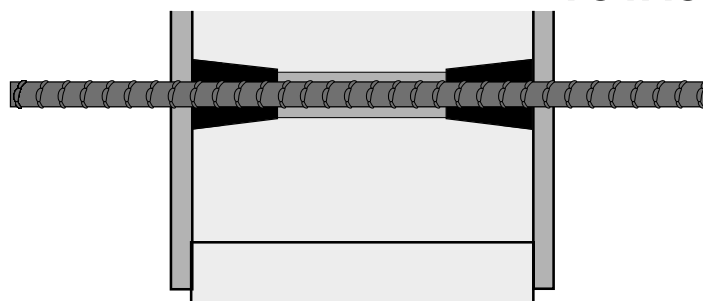

Tapón estriado estanco y muro visto Ø22
Plug. waterproof raw wall Ø22
Bouchon strié étanche et mur apparent Ø22

916083



Tubo rápido encofrado pasamuro Ø22
Fast formwork tube Ø22
Tuyau de passage rapide de coffrage Ø22

916021



Tubo rápido encofrado pasamuro Ø22
Fast formwork tube Ø22
Tuyau de passage rapide de coffrage Ø22

916038



Tubo rápido encofrado pasamuro Ø22
Fast formwork tube Ø22
Tuyau de passage rapide de coffrage Ø22

916045

CÓDIGO CODE	MEDIDAS SIZES/ MESURES	UDS. BOLSA UNITS BAG UNITÉS SACHET	UDS. CAJA UNITS PACK UNITÉS PACK	UDS. PALET UNITS PALLET UNITÉS PALLET
916083	22 mm	500	6 bolsas / 3.000	42 cajas / 126.000
916021	200 mm	-	200	28 cajas / 5.600
916038	250 mm	-	150	28 cajas / 4.200
916045	300 mm	-	100	30 cajas / 3.000

*Para otras medidas, consultar. / *For other measurements, consult. / *Pour d'autres mesures, consulter.



3.4.4. BERENJENO Y JUNTA DILATACIÓN CHAMFER STRIP AND DILATATION JOINT LITEAU TRIANGULAIRE ET JOINT DE DILATATION

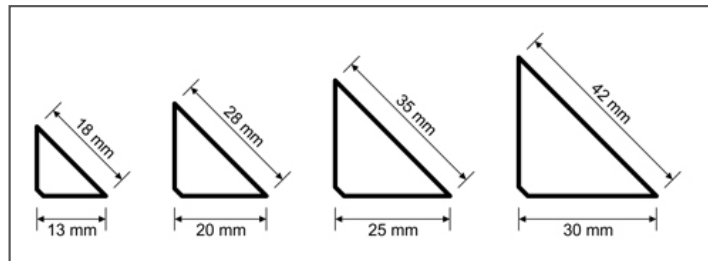
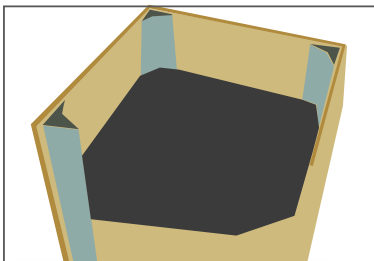
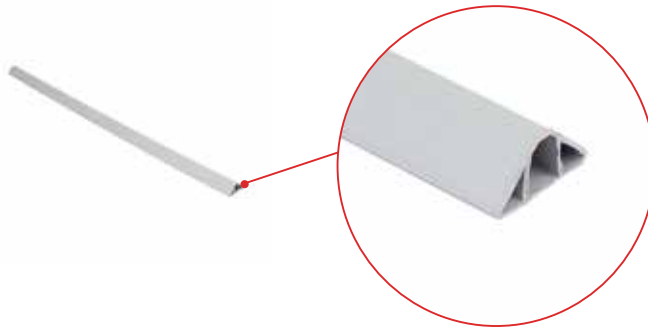

15 mm

916212



20 mm

916168



25 mm

916175



30 mm

916182

CÓDIGO CODE	MEDIDAS SIZES / MESURES	UDS. CAJA UNITS BOX / UNITÉS PACK	CAJAS PALET BOXES PALLET / BOÎTES PALLET
916212	15 mm x 2,50 mts	100	20
916168	20 mm x 2,50 mts	50	20
916175	25 mm x 2,50 mts	50	20
916182	30 mm x 2,50 mts	50	20

JUNTA DE DILATACIÓN DILATATION JOINT JOINT DE DILATATION

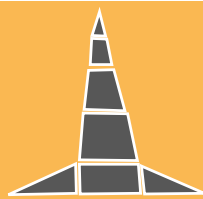

40 mm

916229



80 mm

916236

CÓDIGO CODE	MEDIDAS SIZES MESURES	UDS. CAJA UNITS BOX UNITÉS PACK	CAJAS PALET BOXES PALLET BOÎTES PALLET
916229	40 mm x 2,50 mts	30	30
916236	80 mm x 2,50 mts	20	15

* Para otros colores y medidas consultar a fábrica.

* Check with the company for another sizes and colours.

* Pour d'autres couleurs et tailles, consulter l'usine.

3.4.5. SEPARADORES SIERRA SAW PLASTIC SPACER SÉPARATEUR SCIE

ENCOFRADO
FORMWORK
COFFRAGE



* Longitud: 2mts x tira
* Length: 2mts x strip
* Longueur : 2mts x bande



Separador 25 mm
Spacer 25 mm
Séparateur 25 mm

917417



Separador 30 mm
Spacer 30 mm
Séparateur 30 mm

917424



Separador 40 mm
Spacer 40 mm
Séparateur 40 mm

917431



Separador 50 mm
Spacer 50 mm
Séparateur 50 mm

917448

CÓDIGO CODE	MEDIDAS SIZES / MESURES	UDS. ATADO UNITS TIED / UNITÉS ATTACHÉ	ATADO POR PALET TIED PER PALLET / ATTACHÉ PAR PALLET
917417	25 mm x 2 mts	50 (100 mts) Tiras / Strips / Bandes	49 (4.900 mts) Atados / Tied / Attaché
917424	30 mm x 2 mts	50 (100 mts) Tiras / Strips / Bandes	42 (4.200 mts) Atados / Tied / Attaché
917431	40 mm x 2 mts	24 (60 mts) Tiras / Strips / Bandes	76 (2.400 mts) Atados / Tied / Attaché
917448	50 mm x 2 mts	30 (60 mts) Tiras / Strips / Bandes	28 (1.680 mts) Atados / Tied / Attaché

3.4.6. SEPARADOR CONDOR CONDOR SPACER SÉPARATEUR CONDOR

CÓDIGO CODE	MEDIDAS SIZES / MESURES	UDS. BOLSA UNITS BAG / UNITÉS SACHET	UDS. PALET UNITS PALLET / UNITÉS PALLET
917004	20 mm	1.000	90 bolsas / 90.000
917011	30 mm	500	96 bolsas / 48.000
917028	40 mm	500	60 bolsas / 30.000
917035	50 mm	500	36 bolsas / 18.000



REFORZADO
REINFORCED
RENFORCÉ

3.4.7. SEPARADOR TIMÓN RUDDER SPACER SEPARATEUR GOUVERNAIL

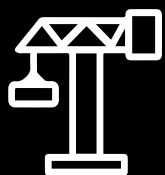

CÓDIGO CODE	MEDIDAS SIZES/ MESURES	Ø VARILLA Ø DIPSTICK / Ø TIGE	UDS. BOLSA UNITS BAG / UNITÉS SACHET	UDS. PALET UNITS PALLET / UNITÉS PALLET
917110	25 mm	6 - 12	1.000	60 bolsas / 60.000
917127	30 mm	6 - 14	500	78 bolsas / 39.000
917134	35 mm	6 - 14	500	44 bolsas / 22.000
917141	40 mm	12 - 20	200	84 bolsas / 16.800
917158	50 mm	12 - 20	200	54 bolsas / 10.800
917172	60 mm	12 - 20	200	36 bolsas / 7.200
917455	70 mm	12 - 20	150	33 bolsas / 4.950
917189	70 mm (reforzado)	12 - 20	150	33 bolsas / 4.950

3.4.8. SEPARADORES DE HORMIGÓN CONCRETE SPACER SÉPARATEUR DE BÉTON

ENCOFRADO
FORMWORK
COFFRAGE

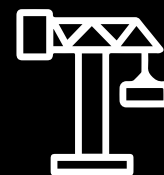

SEPARADORES CUBITO / CONCRETE CUBE SPACERS / CALES BÉTON BLOC

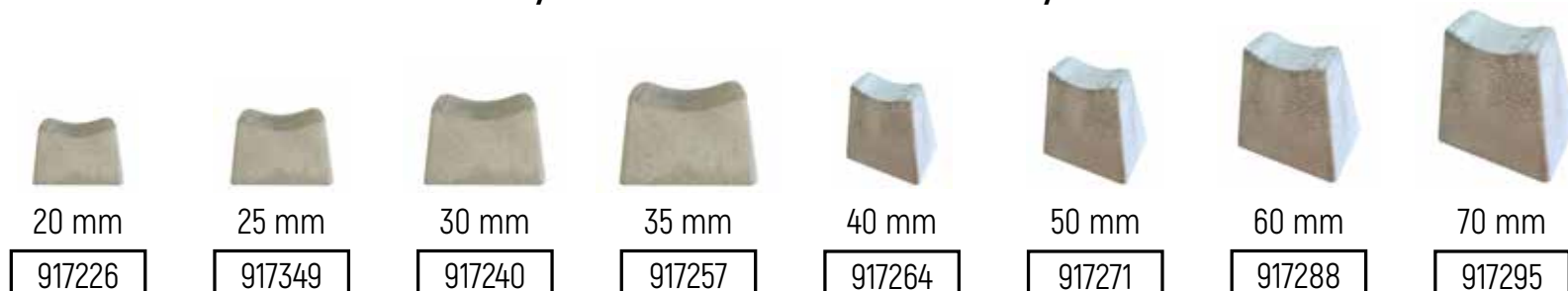

CÓDIGO CODE	MEDIDAS SIZES/ MESURES	UDS. BOLSA UNITS BAG / UNITÉS SACHET	UDS. PALET UNITS PALLET / UNITÉS PALLET
917226	20 mm	700	50 bolsas / 35.000 uds. palet
917233	25 mm	400	50 bolsas / 20.000 uds. palet
917240	30 mm	300	50 bolsas / 15.000 uds. palet
917257	35 mm	250	40 bolsas / 10.000 uds. palet
917264	40 mm	200	40 bolsas / 8.000 uds. palet
917271	50 mm	150	45 bolsas / 6.750 uds. palet
917288	60 mm	125	40 bolsas / 5.000 uds. palet
917295	70 mm	100	40 bolsas / 4.000 uds. palet



* Pedido mínimo palet completo

* Minimum order full pallet

* Commande minimale d'une palette complète

SEPARADOR RETICULAR / RETICULATE SPACER / CALE BÉTON RÉTICULÉ

CÓDIGO CODE	MEDIDAS SIZES/ MESURES	UDS. BOLSA UNITS BAG / UNITÉS SACHET	UDS. PALET UNITS PALLET / UNITÉS PALLET
917301	120 mm	100	60 bolsas / 6.000 uds. palet

917301



34.8. SEPARADORES DE HORMIGÓN CONCRETE SPACER SÉPARATEUR DE BÉTON

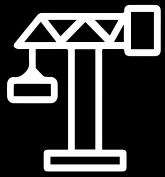

TACO CON ALAMBRE
CONCRETE SPACER WITH WIRE
TACO AVEC CÂBLE



20 mm

917349



25 mm

917356



30 mm

917363



40 mm

917370



50 mm

917387



60 mm

917394

CÓDIGO CODE	MEDIDAS SIZES/ MESURES	UDS. BOLSA UNITS BAG / UNITÉS SACHET	UDS. PALET UNITS PALLET / UNITÉS PALLET
917349	20 mm	500	40 bolsas / 20.000 uds. palet
917356	25 mm	400	50 bolsas / 20.000 uds. palet
917363	30 mm	300	45 bolsas / 13.500 uds. palet
917370	40 mm	250	40 bolsas / 10.000 uds. palet
917387	50 mm	200	40 bolsas / 8.000 uds. palet
917394	60 mm	125	40 bolsas / 5.000 uds. palet

* Pedido mínimo palet completo
* Minimum order full pallet
* Commande minimale d'une palette complète

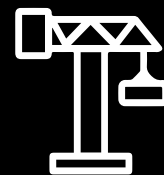

**SEPARADOR TRIVALENTE
CONCRETE TRIVALENT SPACER
CALE BÉTON TRIVALENTE**



917202



917196



917400



917219

CÓDIGO CODE	MEDIDAS SIZES/ MESURES	UDS. BOLSA UNITS BAG / UNITÉS SACHET	UDS. PALET UNITS PALLET / UNITÉS PALLET
917202	20 x 25 x 30 mm	700	40 bolsas / 28.000 uds. palet
917196	35 x 40 x 50 mm	200	50 bolsas / 10.000 uds. palet
917400	35 x 40 x 50 mm	200	50 bolsas / 10.000 uds. palet
917219	45 x 55 x 60 mm	125	40 bolsas / 5.000 uds. palet

* Pedido mínimo palet completo
* Minimum order full pallet
* Commande minimale d'une palette complète



917332



917318



917325

CÓDIGO CODE	MEDIDAS SIZES/ MESURES	UDS. BOLSA UNITS BAG / UNITÉS SACHET	UDS. PALET UNITS PALLET / UNITÉS PALLET
917332	35 mm	100	40 bolsas / 4.000 uds. palet
917318	70 mm	-	475
917325	75 mm	-	240

**REDONDO HORMIGÓN
CONCRETE CIRCULAR SPACER
CALE BÉTON CIRCULAIRE**

* Pedido mínimo palet completo
* Minimum order full pallet
* Commande minimale d'une palette complète



3.5

**CAPAZOS
FLEXITUB
SEAU DE CHANTIER**

**3.5.1. CAPAZOS 170
FLEXITUB
SEAU DE CHANTIER**



CAPAZOS
FLEXITUB
SEAU DE CHANTIER

3.5.1. CAPAZOS FLEXITUB SEAU DE CHANTIER



**CAPAZOS
FLEXITUB
SEAU DE CHANTIER**



Cubo obra 11
Bucket 11
Seau 11

919169



Capazo 14
Flexitub 14
Baquet 14

919107



Cubo 26
Bucket 26
Seau 26

919138



Capazo 26
Flexitub 26
Baquet 26

919114



Capazo 30
Flexitub 30
Baquet 30

919145



Capazo 42
Flexitub 42
Baquet 42

919152



Capazo 65
Flexitub 65
Baquet 65

919121

CÓDIGO CODE	L x A x H MEDIDAS SIZES MESURES	CAPACIDAD CAPACITY CAPACITÉ	UDS. ATADO UNITS TIED UNITÉS ATTACHÉ	ATADO POR PALET TIED PER PALLET ATTACHÉ PAR PALETTE
919169	225 x 320 x 225 mm - 8.86 × 12.60 × 8.86 in	11 L - 3US gal	12	50
919107	410 x 330 x 240 mm - 16.14 × 12.99 × 9.45 in	14 L - 3,7US gal	12	64
919138	350 x 350 x 330 mm - 350 x 350 x 330 mm	26 L - 7US gal	12	64
919114	400 x 350 x 340 mm - 15.75 × 13.78 × 13.39 in	26 L - 7US gal	12	80
919145	470 x 430 x 280 mm - 18.50 × 16.93 × 11.02 in	30 L - 8US gal	12	48
919152				
919664				
919671	490 x 430 x 385 mm - 19.29 × 16.93 × 15.16 in	42 L - 11US gal	12	50
919688				
919121	615 x 560 x 380 mm - 24.21 × 22.05 × 14.96 in	65 L - 17US gal	12	60

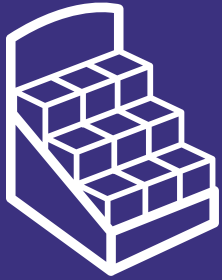

EXPOSITORES PARA PUNTO DE VENTA
POINT OF SALE DISPLAYS
PRÉSENTOIRS DE POINT DE VENTE

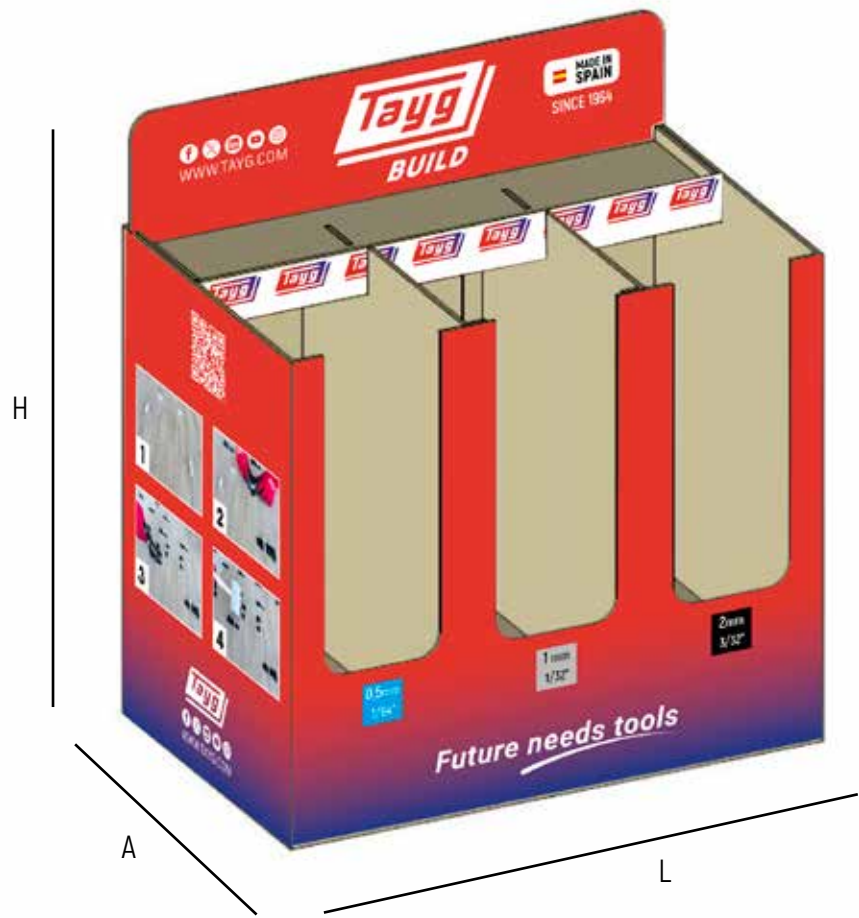

999413

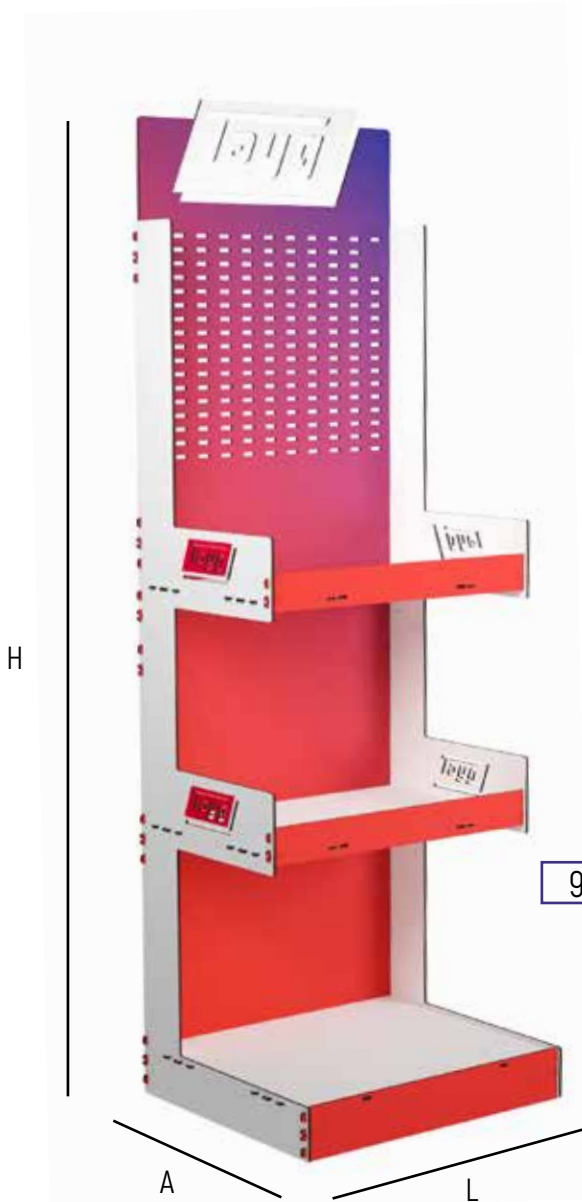

999376



999208



999246

*Consultar condiciones.
*Check the conditions.
*Consulter les conditions.



CÓDIGO CODE	DESCRIPCIÓN DESCRIPTION
999376	Mueble expositor- L 625 x A 530 x H 1950mm Display Présentoir
999413	Expositor palet nivelación - L 1170 x A 740 x H 1300mm Pallet levelling display stand Présentoir à palettes à nivellement
999208 general* 999246 build*	Corner expositor central - L 1200 x A 660 x H 2130 Central display corner Corner présentoir central
999383	Expositor bolsas - L 625 x A 516 x H 1270mm Bags display Présentoir de boîtes
999307	Expositor sobremesa TAYG BUILD - L 220 x A 230 x H 225mm Table display TAYG BUILD Présentoir de table TAYG BUILD

ICONOGRAFÍA GENERAL

GENERAL ICONOGRAPHY

ICONOGRAPHIE GÉNÉRALE



Colores especiales disponibles en todos los colores RAL bajo pedido. Consultar

Special colours available in all RAL colours under request. Please send us your enquiry.

Couleurs spéciales disponibles dans toute gamme de coloris RAL, sur demande.



Soporta 120kg
Supports up to 120kg
Supporte 120kg



Asa de Seguridad Antiapertura
Anti Opening Lock System
Poignée de sécurité anti ouverture

IML

Personalizable con tecnología IML
Customizable with IML technology
Personnalisable avec la technologie IML



Tecnología de RFID
RFID technology
Technologie RFID



Soporta 175kg por estante
Up to 175 kg per shelf
Jusqu'à 175 kg par étagère



Montaje en 10 minutos
Assembly in 10 minutes
Assemblée en 10 minutes



Protección para niños
Protection for children
Protection pour enfants



Alta resistencia
High strength
Haute resistance



Uso industrial
Industrial use
Usage industriel



Apto para uso alimentario.
Registro sanitario n° 3904321/V
Food Graded. Health registration n° 3904321/V
Apte pour l'utilisation alimentaire.
Registre sanitaire n° 3904321/V



Eficiencia logística
Logistic efficiency
Efficacité logistique



Personalizable
Customizable
Personnalisable



Tapón en el interior
Plug inside
Branchez à l'intérieur



No se necesitan herramientas para su montaje
No tools are needed for assembly
Aucun outil n'est nécessaire pour l'assemblage



Heavy duty. Soporta 80kg por estante
Heavy duty. Up to 80 kg per shelf
Heavy duty. Jusqu'à 80 kg par étagère



Grandes formatos
Big sizes
Grand formats



LISTA DE PACKING
PACKING LIST
LISTE D'EMBALLAGE

Escanea el código QR
Scan QR code
Scanner le code QR





WWW.TAYG.COM



Industrias Tayg, S.L.U.

Avda. Real de Madrid Norte, 70 - 46469 Beniparrell - Valencia (Spain)

Tlf. +34 96 121 24 62 | info@tayg.com | www.tayg.com